

**SA400**  
**minifloppy™**  
**Diskette Storage Drive**

**Service Manual**

**SA400**  
**minifloppy™**  
**Diskette Storage Drive**

**Service Manual**

## **PREFACE**

This service manual contains all the information required to service the SA 400 MiniFloppy drive in the field. The service manual is divided into 3 sections:

Section 1 Theory of Operations

Section 2 Maintenance Manual

Section 3 Illustrated Parts Catalog

Each section contains its own Table of Contents.

For information on the SA 400 drive specifications, interfacing, track formats, and applications notes refer to Shugart Associates OEM manual P/N 54102.

# Theory of Operations

---

## Section 1

# Table of Contents

---

1.0	Theory of Operations . . . . .	1
1.1	General Operations . . . . .	1
1.2	Head Positioning . . . . .	1
1.3	Diskette Spindle Drive . . . . .	2
1.4	Read/Write Head . . . . .	2
1.5	Recording Format . . . . .	2
1.6	Bit Cell . . . . .	3
1.7	Byte . . . . .	3
1.8	Tracks . . . . .	4
1.9	Track Format . . . . .	4
1.10	Sector Recording Format . . . . .	4
1.11	Soft Sector Recording Format . . . . .	4
2.0	Drive Motor Control . . . . .	6
3.0	Drive Selection . . . . .	7
3.1	Head Load . . . . .	7
3.2	Single Drive System . . . . .	7
3.3	Multiple Drive System . . . . .	7
4.0	Index Detector . . . . .	8
5.0	Track Zero Indication . . . . .	9
6.0	Track Accessing . . . . .	10
6.1	Stepper Motor . . . . .	10
6.2	Stepper Control . . . . .	10
6.3	Step Out . . . . .	10
6.4	Step In Mode . . . . .	10
7.0	Read/Write Operations . . . . .	13
8.0	Read/Write Head . . . . .	16
9.0	Write Circuit Operation . . . . .	17
10.0	Read Circuit Operation . . . . .	18
11.0	Write Protect . . . . .	19
12.0	Interface . . . . .	20
12.1	J1/P1 Connector . . . . .	20
12.2	D.C. Power . . . . .	20
12.3	Input/Output Lines . . . . .	20

# List of Illustrations

---

1. Functional Diagram . . . . .	2
2. Data Pattern . . . . .	2
3. Bit Cell . . . . .	3
4. Byte . . . . .	3
5. Data Bytes . . . . .	3
6. Hard Sector Format . . . . .	4
7. Soft Sector Format . . . . .	5
8. Motor Control Functional Diagram . . . . .	6
9. Drive Select Functional Diagram . . . . .	7
10. Index Detector Logic . . . . .	8
11. Index Timing Diagram . . . . .	8
12. Track 00 Indication Diagram . . . . .	9
13. Track 00 Timing Diagram . . . . .	9
14. Step Out Logic . . . . .	10
15. Stepper Control Functional Diagram . . . . .	11
16. Step Timing Diagram . . . . .	12
17. Step In Logic . . . . .	12
18. Bit Cell . . . . .	14
19. Basic Read/Write Head . . . . .	14
20. Recorded Bit . . . . .	14
21. Reading A Bit . . . . .	15
22. 1F and 2F Recording Flux and Pulse Relationship . . . . .	15
23. Read/Write Head . . . . .	16
24. Write Circuit Functional Diagram . . . . .	17
25. Read Circuit Functional Diagram . . . . .	18
26. Write Protect Functional Diagram . . . . .	19
27. D.C. Power . . . . .	20
28. SA400 Interface Connections . . . . .	21
29. Interface Signal Driver/Receiver . . . . .	21

## **1.0 THEORY OF OPERATIONS**

### **1.1 GENERAL OPERATIONS**

The SA 400 Minifloppy Drive consists of read/write and control electronics, drive mechanism, motor control, read/write head, track positioning mechanism, and the removable Diskette. These components perform the following functions:

- Interpret and generate control signals.
- Move read/write head to the desired track.
- Read and write data
- Maintain correct diskette speed.

The relationship and interface signals for the internal functions of the SA 400 are shown in Figure 1.

The Head Positioning Actuator Cam positions the read/write head to the desired track on the Diskette. The Head Load Actuator loads the Diskette against the read/write head and data may then be recorded or read from the Diskette.

The drive has two (2) PCB's, one is for the drive motor control and the other is the drive PCB. The electronics packaged on the drive PCB contains:

1. Index Detector Circuits
2. Head Position Actuator Driver
3. Head Load Actuator Driver
4. Read/Write Amplifier and Transition Detector
5. Step Control Logic
6. Track Zero Sensing Circuits
7. Write Protect

The drive motor control PCB contains the following electronics:

1. Motor on & off circuitry
2. Motor speed control

### **1.2 HEAD POSITIONING**

An electrical stepping motor drives the Head Position Actuator Cam which positions the read/write head. The stepping motor rotates the actuator cam clockwise or counter-clockwise. The using system increments the stepping motor to the desired track. Each step consists of 2 steps to the stepper motor for each step pulse supplied on the interface.

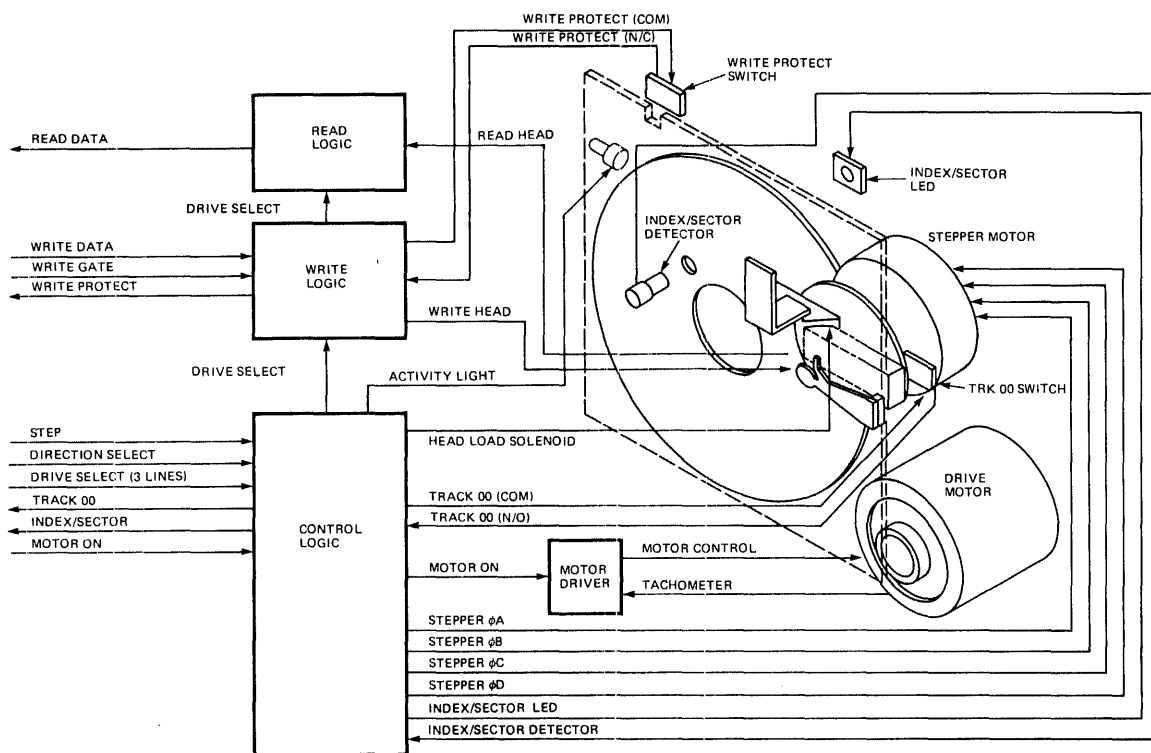

FIGURE 1. FUNCTIONAL DIAGRAM

### 1.3 DISKETTE SPINDLE DRIVE

The Diskette D.C. drive motor rotates the spindle at 300 rpm through a belt-drive system. 50 or 60 Hz operation is accommodated without any changes. A Clamping Hub moves in conjunction with the Hub frame that precisely clamps the Diskette to the spindle hub. The motor is started by making the interface signal "motor on" true and is stopped by making this signal false.

### 1.4 READ/WRITE HEAD

The read/write head is a ceramic head and is in direct contact with the Diskette. The head surface has been designed to obtain maximum signal transfer to and from the magnetic surface of the Diskette with minimum Head/Diskette wear.

The SA 400 ceramic head is a single element read/write head with straddle erase elements to provide erased areas between data tracks. Thus, normal tolerance between media and drives will not degrade the signal to noise ratio and insures Diskette interchangeability.

The read/write head is mounted on a carriage which is located on the Head Position Actuator Cam and is driven thru a cam follower. The Disk-

ette is held in a plane perpendicular to the read/write head by one platen located on the base casting. The Diskette is loaded against the head with a felt load pad actuated by the head load solenoid.

### 1.5 RECORDING FORMAT

The format of the data recorded on the Diskette is totally a function of the host system. Data is recorded on the Diskette using frequency modulation as the recording mode, i.e., each data bit recorded on the diskette has an associated clock bit recorded with it, this is referred to as FM. Data written on and read back from the diskette takes the form as shown in Figure 2. The binary data pattern shown represents a 101. Two recording frequencies are used. 1F which is 0 bit and 2F which is a 1 bit. The 1F frequency is 62.5 KHz and 2F is 125.0 KHz.

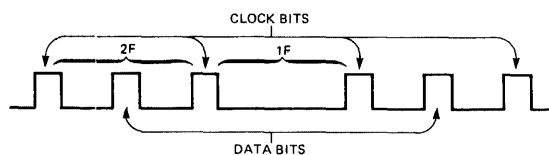

FIGURE 2. DATA PATTERN



### 1.6 BIT CELL

As shown in Figure 3, the clock bits and data bits (if present) are interleaved. By definition, a Bit Cell is the period between the leading edge of one clock bit and the leading edge of the next clock bit. A bit cell time is  $8\mu$  sec from clock to clock.

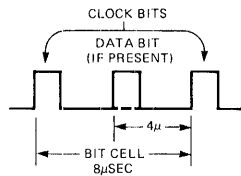

FIGURE 3. BIT CELL

### 1.7 BYTE

A Byte, when referring to serial data (being written onto or read from the disc drive), is defined as

eight (8) consecutive bit cells. The most significant bit cell is defined as bit cell 0 and the least significant bit cell is defined as bit cell 7. When reference is made to a specific data bit (i.e., data bit 3), it is with respect to the corresponding bit cell (bit cell 3).

During a write operation, bit cell 0 of each byte is transferred to the disc drive first with bit cell 7 being transferred last. Correspondingly, the most significant byte of data is transferred to the disc first and the least significant byte is transferred last.

When data is being read back from the drive, bit cell 0 of each byte will be transferred first with bit cell 7 last. As with reading, the most significant byte will be transferred first from the drive to the user. Figure 4 illustrates the relationship of the bits within a byte and Figure 5 illustrates the relationship of the bytes for read and write data.

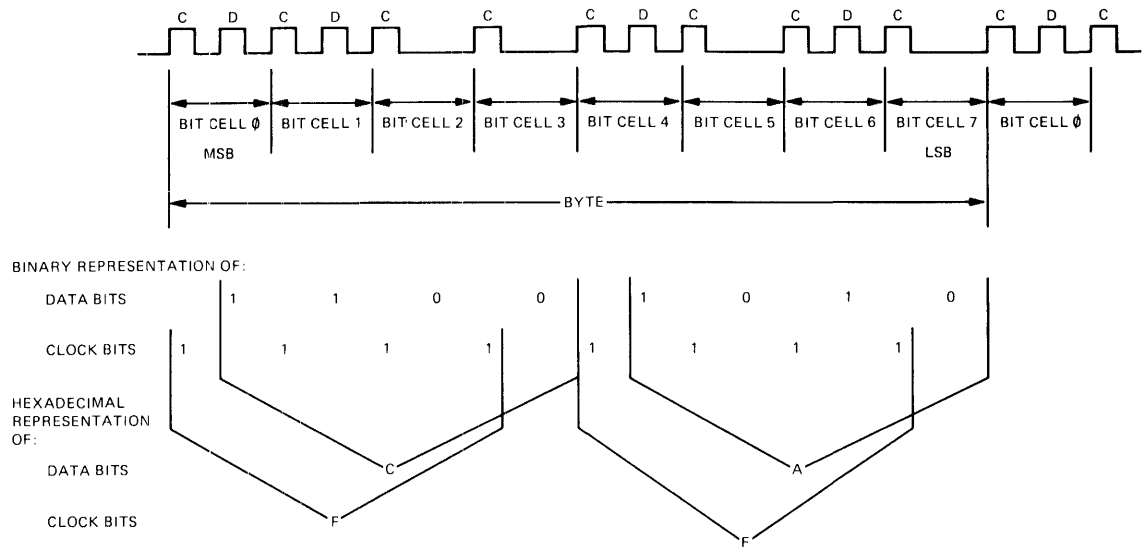

FIGURE 4. BYTE

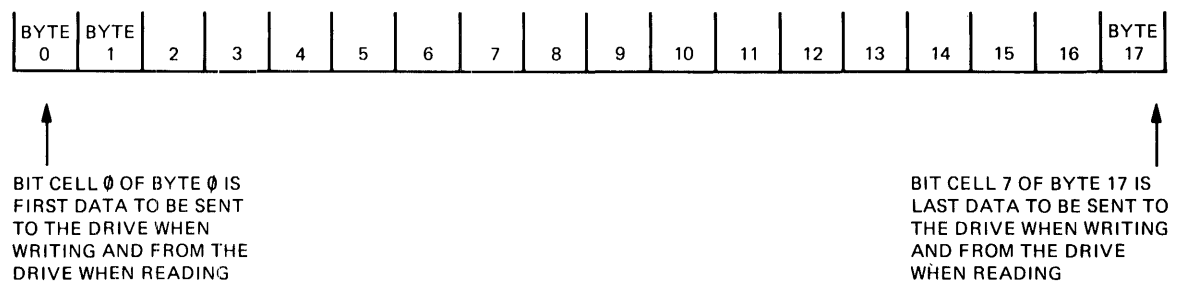

FIGURE 5. DATA BYTES

### 1.8 TRACKS

The SA 400 Minifloppy drive is capable of recording up to 35 tracks of data. The tracks are numbered 0-34. Each track is made available to the read/write head by accessing the head with a stepper motor and carriage assembly. Track 00 is the outer most track with track 34 being the innermost track. Track accessing will be covered in Section 3.

Basic Track Characteristics:

No. bits/track	25,000 bits
Bit per inch (inside)	2,581 BPI
Tracks per inch	48 TPI
Access time	40 msec

### 1.9 TRACK FORMAT

Tracks may be formatted in numerous ways and is dependent on the using system. The SA 400 can use hard sector recording with SA105 and SA107 media or soft-sectoring using SA104 media.

### 1.10 HARD SECTOR RECORDING FORMAT

In this Format, the using system may record up to 10 or 16 sectors (records) per track. Each track is started by a physical index pulse and each sector is started by a physical sector pulse. This type of recording is called hard sectoring. Figure 6 shows some typical Sector Recording Formats. The using system must do the sector separation. For additional information on sector separation and formatting requirements. Refer to the SA 400 OEM Manual.

### 1.11 SOFT SECTOR RECORDING FORMAT

In this Format, the using system may record one long record or several smaller records. Each track is started by a physical index pulse and then each record is preceded by a unique recorded identifier. This type of recording is called soft sectoring. Figure 7 shows the soft sector format for 18 sectors and 128 bytes. Refer to the SA 400 OEM Manual for further formatting information.

#### SA 400 HARD SECTOR FORMAT

SECTOR SEPARATION DONE BY THE USING SYSTEM  
FM RECOMMENDED FORMAT

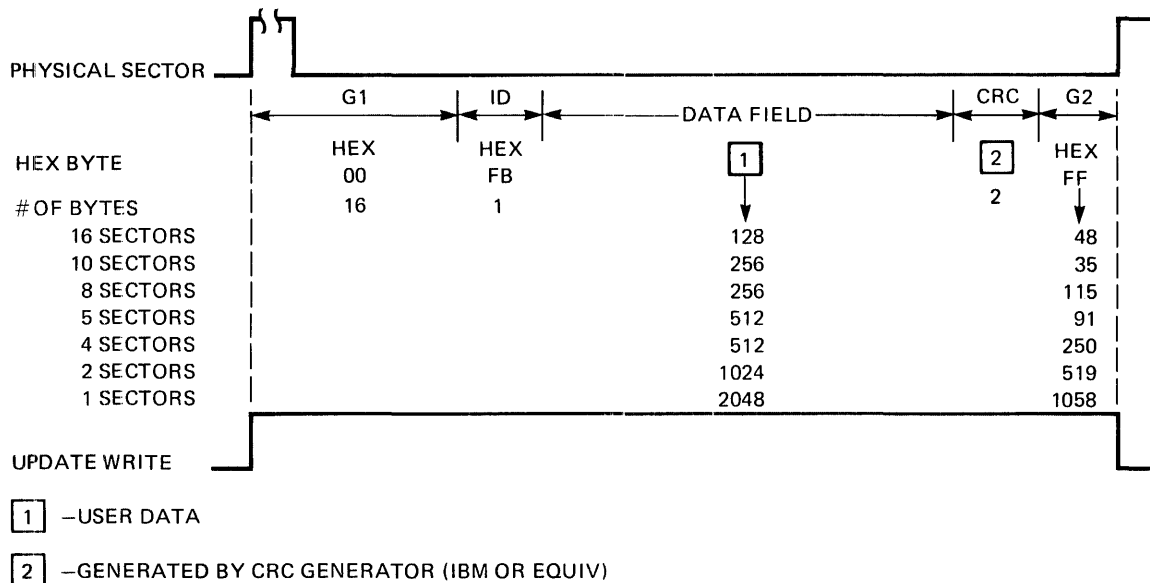

FIGURE 6. HARD SECTOR FORMAT

5

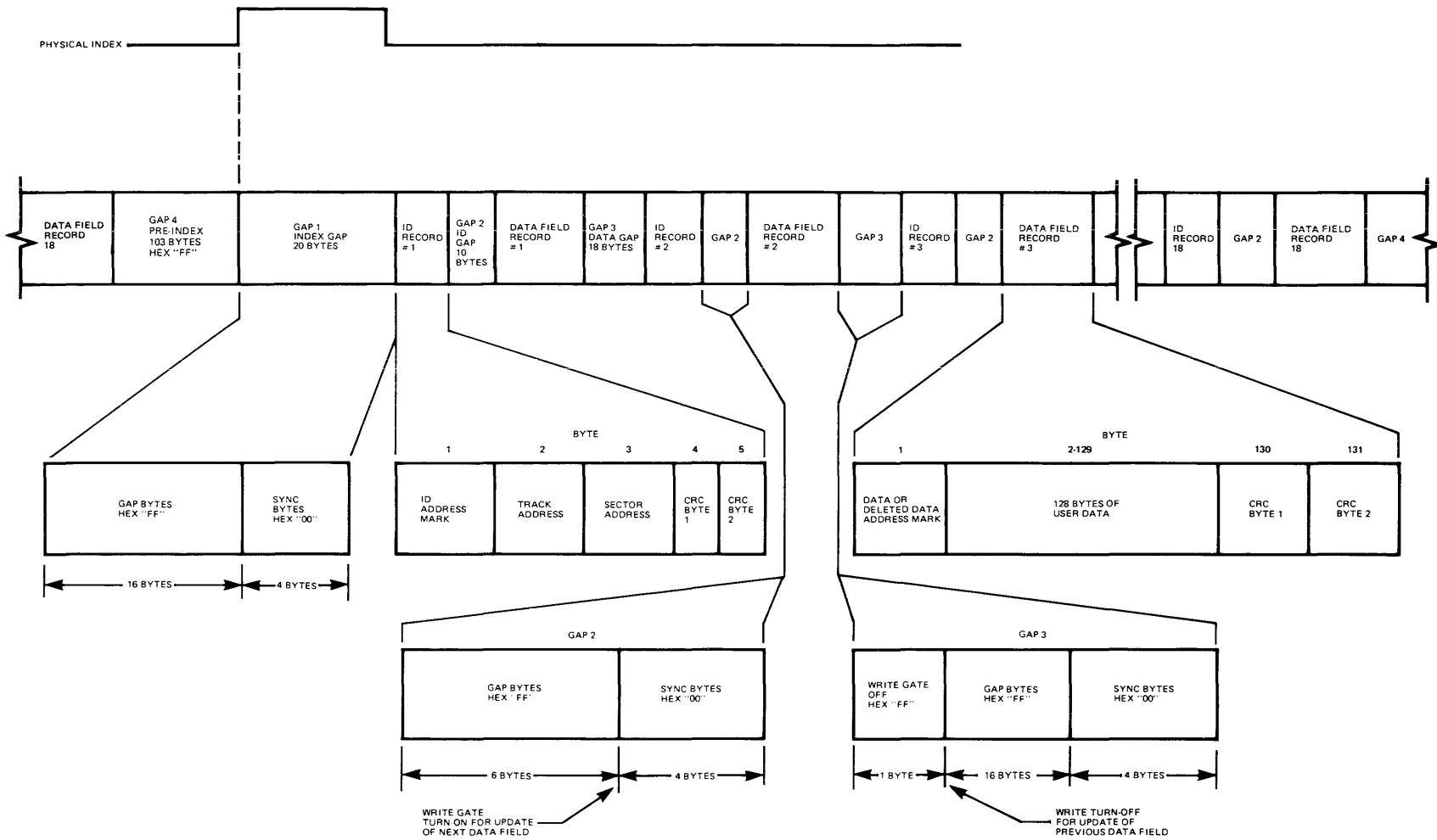

FIGURE 7. SOFT SECTOR FORMAT (18 SECTORS PER TRACK)

## 2.0 DRIVE MOTOR CONTROL

- Start/Stop
- Speed Control
- Over Current Protection
- Speed Adjust

The motor used in the SA 400 is a DC drive motor and has a separate motor on and off interface line. After activating the motor on line, a 1 second delay must be introduced to allow proper motor speed before reading or writing.

When motor on is activated to PIN 16 on the drive PCB this will start the motor by causing current to flow thru the motor windings. Figure 8 shows the functional diagram of the motor speed control circuit. The motor speed control utilizes an integral brushless tachometer. The output voltage signal from this tachometer is compared to a voltage/frequency reference level. The output from the voltage/frequency comparator will control the necessary current to maintain a constant motor speed of 300 RPM. Motor speed adjustment changes the  $V_{ref}$  thru a Potentiometer.

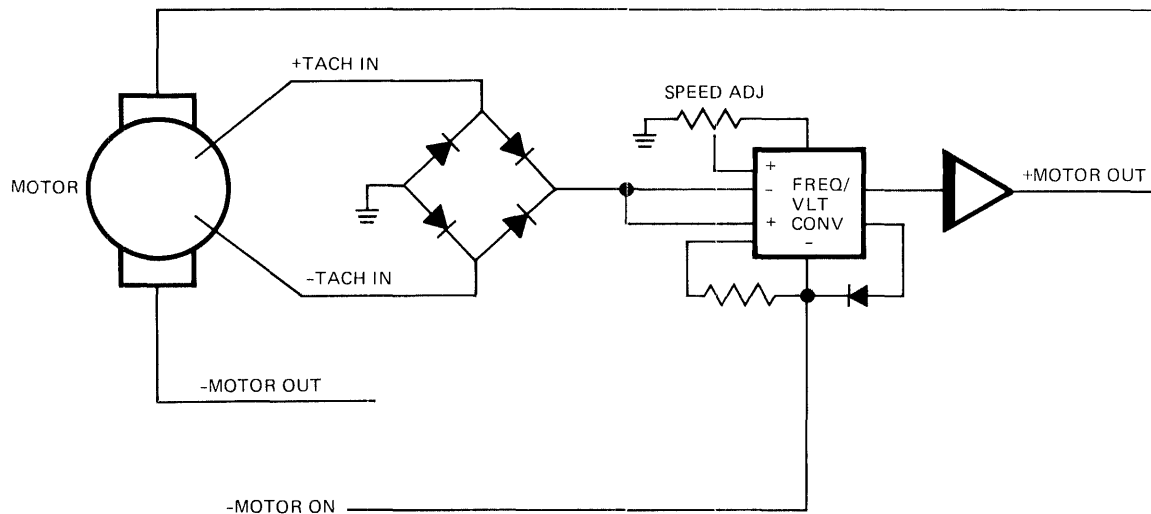

FIGURE 8. MOTOR CONTROL FUNCTIONAL DIAGRAM

### 3.0 DRIVE SELECTION

#### 3.1 HEAD LOAD

When the shunt block position HL is shorted the head will load, by energizing the head load solenoid, when drive select is brought to an active low. Reference Figure 9.

If the shunt block is positioned so HL is open and MH is shorted the head will load with— Motor On signal, irregardless of the state of drive select. Reference Figure 9.

#### 3.2 SINGLE DRIVE SYSTEM

With MX jumper shorted the input to the or gate for output enable is at a low level. This causes the signal output enable to always be true when the

drive is powered on. Activating any drive select line will light the activity lite and enable reading and writing if the motor is running and the head is loaded. Refer to Figure 9 for the logic required.

#### 3.3 MULTIPLE DRIVE SYSTEM

There are 3 drive select lines. In multiple drive systems leave the jumper uncut in the shunt block for the drive number you wish to select. MX must be cut for the input & output to be daisy chained. With MX cut drive select must be true in order to activate output enable which in turn gates the output lines lites the activity lite and conditions the input lines. Reading and writing can now be performed if the motor is running and the head is loaded. Figure 9 is the drive select functional diagram.

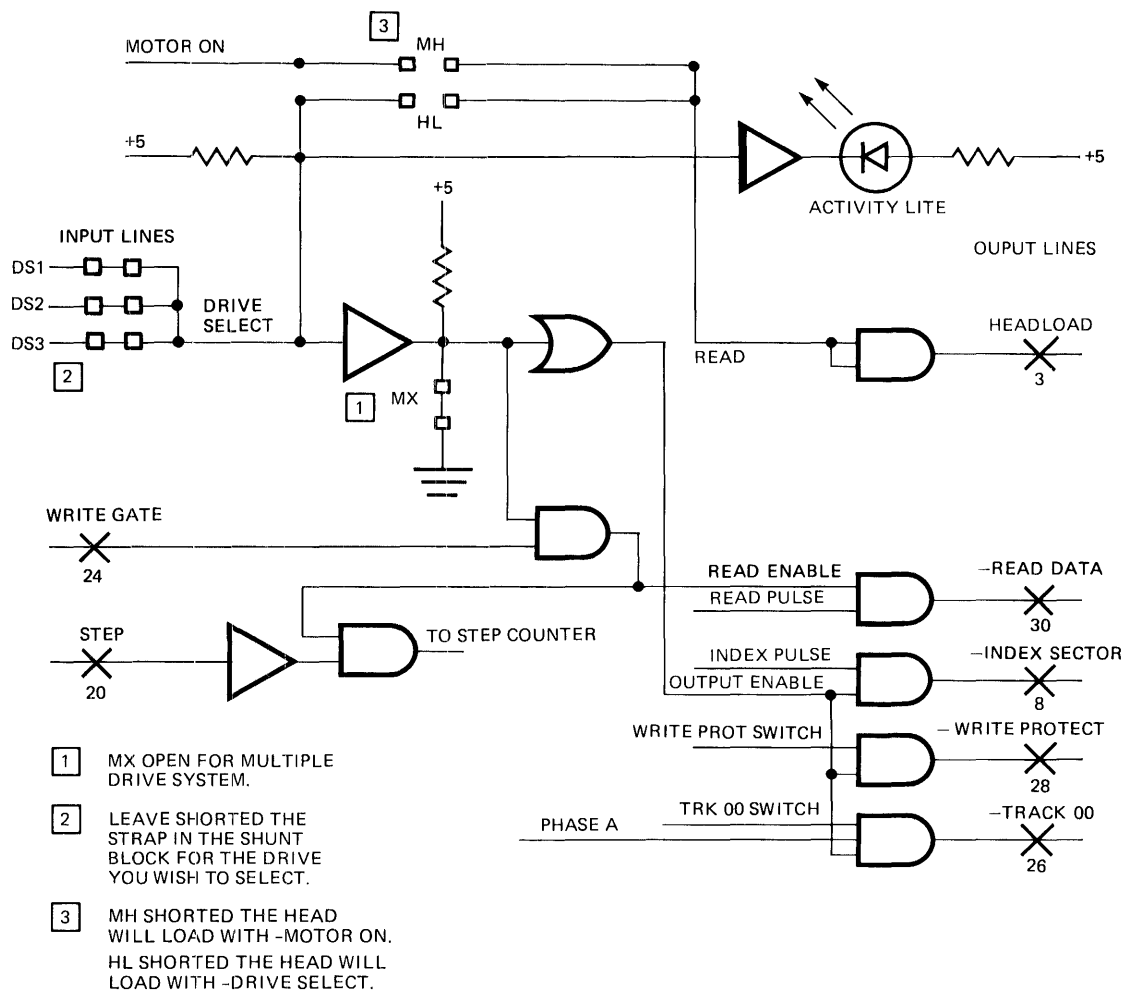

FIGURE 9. DRIVE SELECT FUNCTIONAL DIAGRAM

#### 4.0 INDEX DETECTOR

Each time an index or sector hole is moved past the index photo detector, a pulse is formed. This pulse is present on the interface as index/sector pin 8. Without a Diskette in the drive the output line will be low so the using system must look for a transition to be a valid signal. The detector output is fed into a schmidt trigger with a level trigger latch back to maintain pulse stability, while shaping the pulse. With output enable true this pulse will be on the interface as a negative going pulse. Refer to figures 10 and 11 for logic required and timings. Shown is the output from a soft sector Diskette.

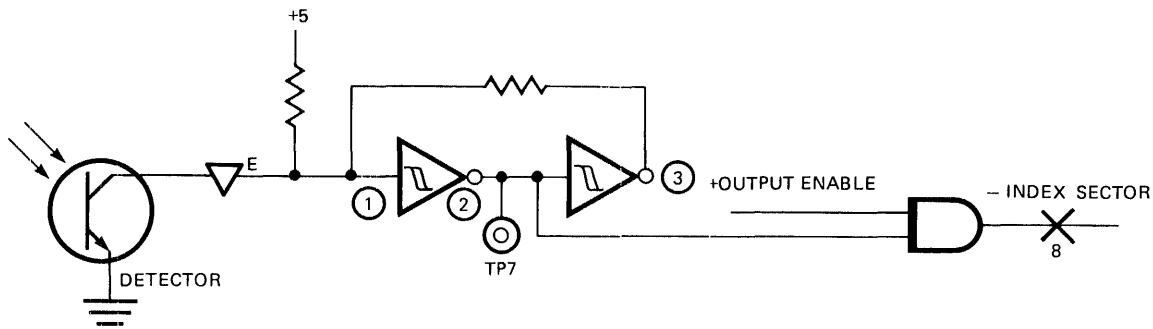

FIGURE 10. INDEX DETECTOR LOGIC

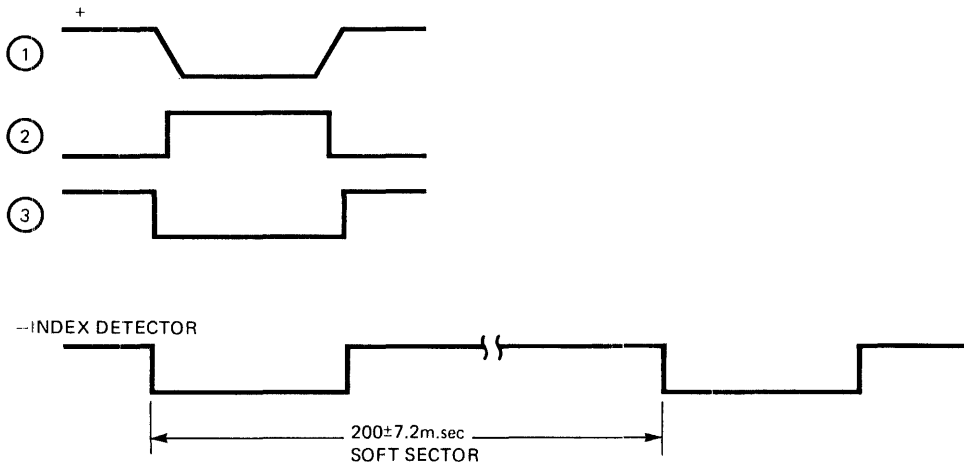

FIGURE 11. INDEX TIMING DIAGRAM

## 5.0 TRACK ZERO INDICATION

Track 00 signal (pin 26) is provided to the using system to indicate when the read/write head is positioned on track zero. Figures 12 & 13 show the logic and timing for the track zero indication. The track zero micro switch is actuated by the carriage between track one and track zero. When the carriage is stepped to track 00 stepper phase A is Anded with the output from the track 00 switch.

The output from this And gate conditions another And gate and its other leg is output enable which is true when the drive is selected in a multiple drive system or on power on in a single drive system. These conditions will cause a TRK 00 indication to the interface. Reference Figure 12 for the logic required.

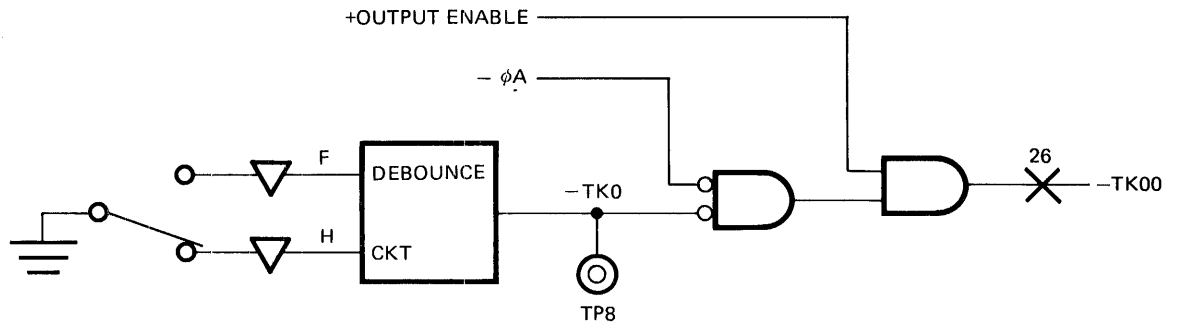

FIGURE 12. TRACK 00 INDICATION DIAGRAM

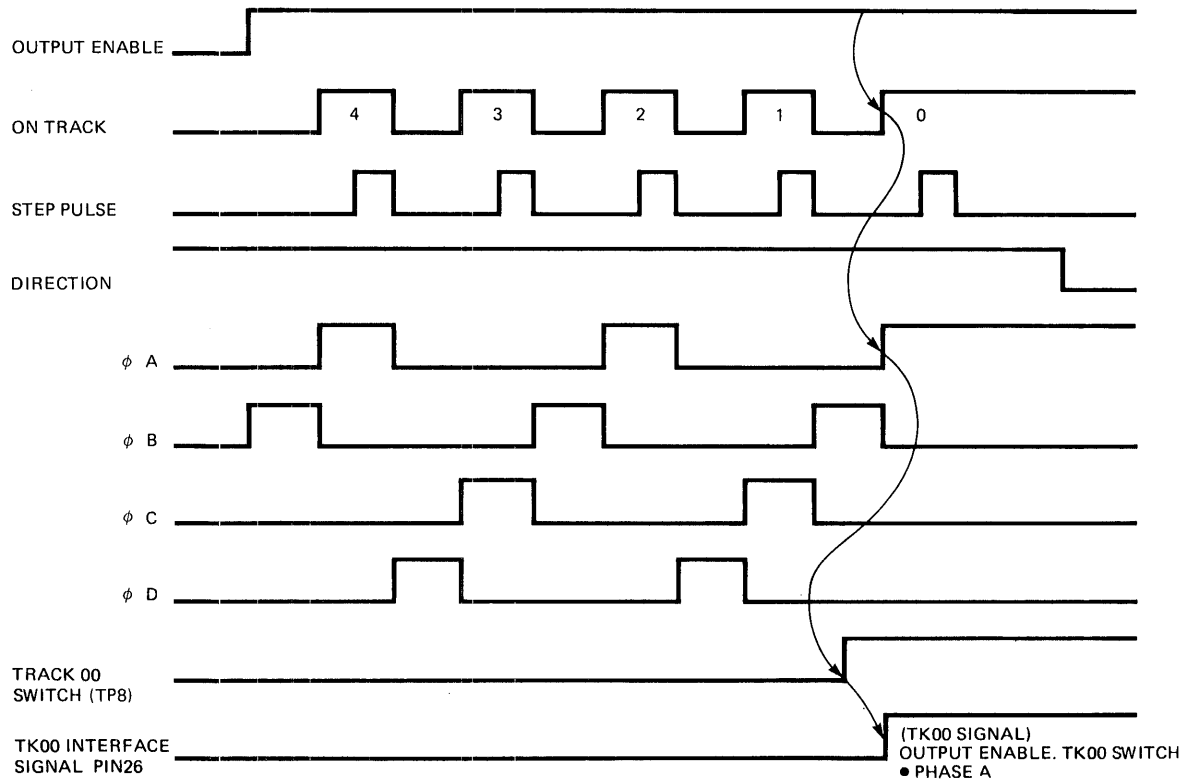

FIGURE 13. TRACK 00 TIMING DIAGRAM

## 6.0 TRACK ACCESSING

- Stepper Motor (4 Phase)
- Stepper Control Logic
- Reverse Seek
- Forward Seek
- Track Zero Indication

Seeking the read/write head from one track to another is accomplished by selecting the desired direction utilizing the Direction Select Interface line, loading the read/write head, and then pulsing the Step line. Multiple track accessing is accomplished by repeated pulsing of the Step line with write gate inactive until the desired track has been reached. Each pulse on the Step line will cause the read/write head to move one track either in or out depending on the Direction Select line.

### 6.1 STEPPER MOTOR

The 4 phase stepper motor turns the head actuator cam in 2 step increments per track. Two increments will move the head one track via a ball bearing follower which is attached to the carriage assembly. This follower rides in a spiral groove in the face of the actuator cam.

The stepper motor has 4 phases. Phase A and phase C are the active positions which are energized when the head is on track. The phases B and D are transient states. Two one shots to the stepper counter logic provides the 2nd step pulse approximately 11 milliseconds after the step line goes negative providing the drive is selected and read enable is true.

### 6.2 STEPPER CONTROL

During Power on Reset time the stepper control shift register is reset to zero. This will cause phase

A to be energized in the stepper. "Figure 15 and 16 shows the stepper control logic and timing."

With drive select and read enable true, this provides the conditions which allows the step pulse to clock the clock input to the stepper control shift register. As the stepper control shifts from one phase to another the outputs are fed back to the 2nd pulse generator s/s. When a step pulse causes the stepper counter to go from its on track phase via the clock input the two step s/s is fired. In approximately 11 milliseconds a 2nd clock to the shift register is provided, this causes the stepper motor to step from its transient phase B or D to the next on track phase A or C. This is the method that causes the stepper to step 2 times for each step pulse on the interface. The circuit will also interlock any possibility of writing on the transient phases B and D.

The stepper control is a 4 bit parallel access shift register with J and K inputs. It is used in the shift mode when stepping out and in the load mode when stepping in. Only the A B and C outputs are used. The 4th output is D' and is true when the other outputs are zero.

### 6.3 STEPOUT

Figure 14 shows the logic for how the bit for stepping is shifted when direction is high and the shift register is in a shift mode or step out.

### 6.4 STEP IN MODE

When direction is low the drive is in a step in mode. The shift register is in a load mode. Its outputs are being used to load the inputs. Figure 17 shows the logic on this and how the outputs are shifted. Reference figure 16 for timing. Again only A B & C outputs are used, the 4th output is D'.

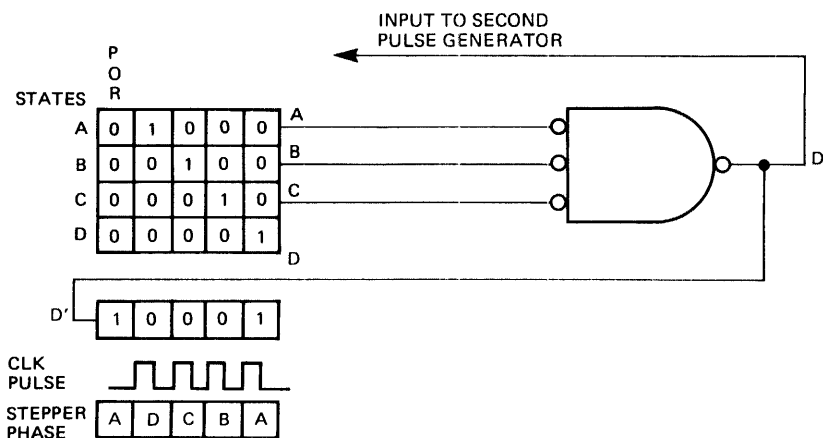

FIGURE 14. STEP OUT LOGIC



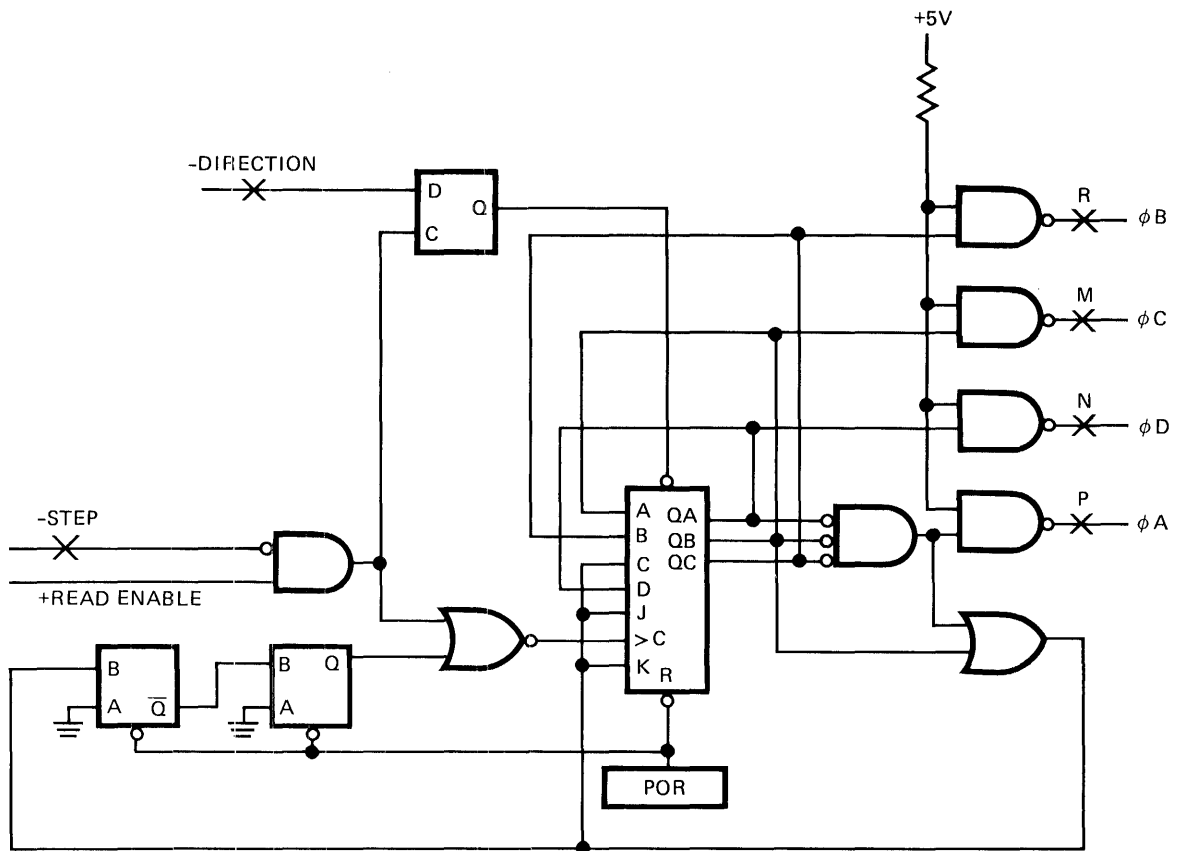

FIGURE 15. STEPPER CONTROL FUNCTION DIAGRAM

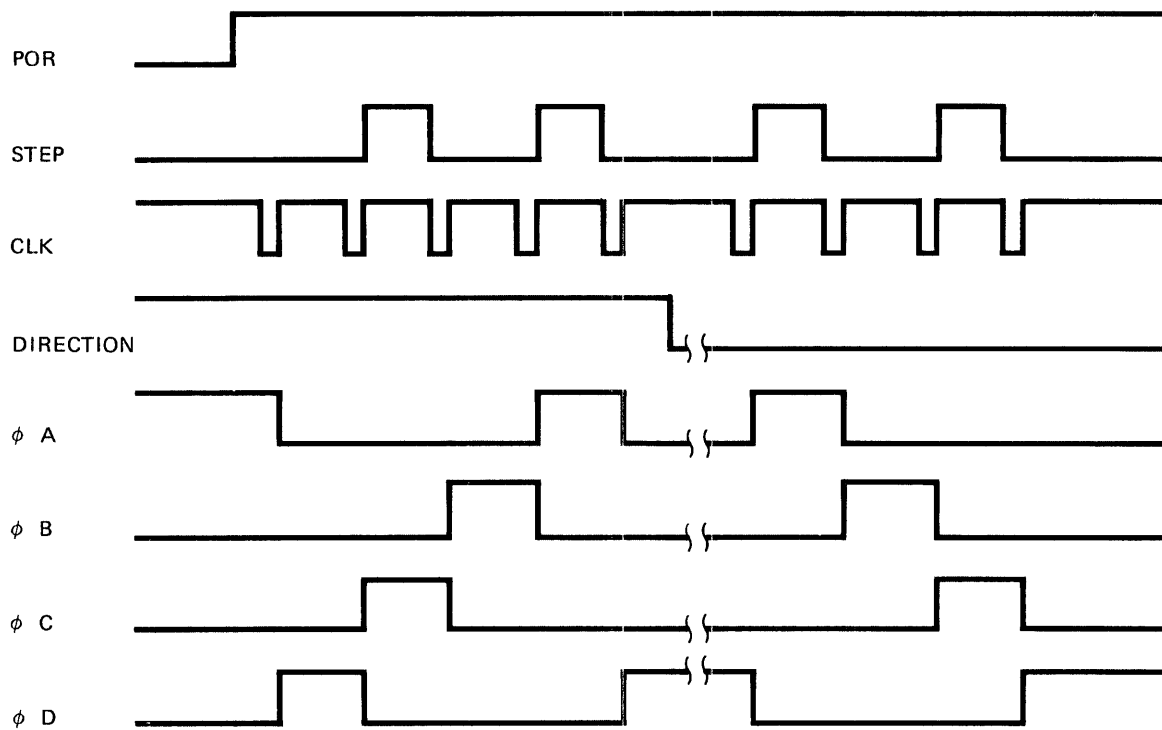

FIGURE 16. STEP TIMING DIAGRAM

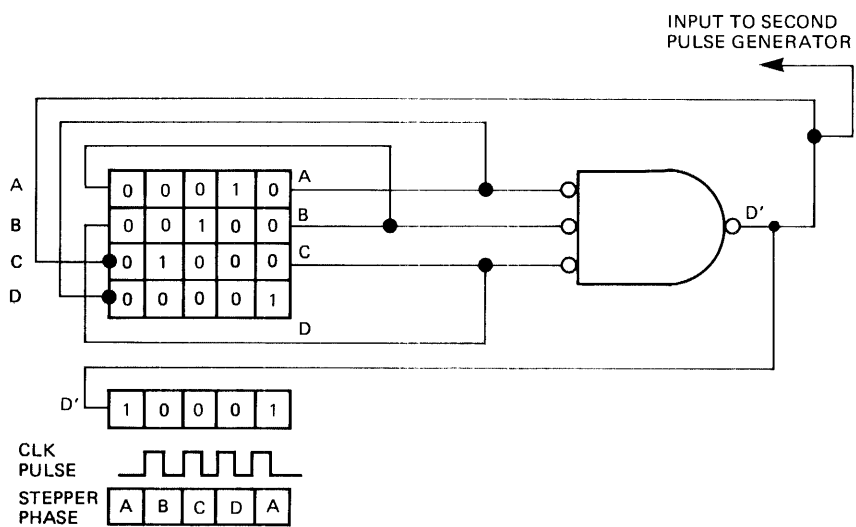

FIGURE 17. STEP IN LOGIC

## 7.0 READ-WRITE OPERATIONS

- SA 400 Minifloppy uses double frequency NRZI recording method.
- The read/write head, in general, is a ring with a gap and a coil wound at some point on the ring.
- During a write operation, a bit is recorded when the flux direction in the ring is reversed by rapidly reversing the current in the coil.
- During a read operation, a bit is read when the flux direction in the ring is reversed as a result of a flux reversal on the diskette surface.

**7.1** The SA 400 drive uses the double-frequency (2F) longitudinal non return to zero (NRZI) method of recording. Double frequency is the term given to the recording system that inserts a clock bit at the beginning of each bit cell time thereby doubling the frequency of recorded bits. This clock bit, as well as the data bit, are provided by the using system. See Figure 18.

**7.2** The read/write head is a ring with a gap and a coil wound some point on the ring. When current flows through the coil, the flux induced in the ring fringes at the gap. As the diskette recording surface passes by the gap, the fringe flux magnetizes the surface in a longitudinal direction. See Figure 19.

**7.3** The drive writes 2 frequencies 1F 62.5 KHz and 2F 125 KHz. During a write operation, a bit is recorded when the flux direction in the ring is reversed by rapidly reversing the current in the coil. The fringe flux is reversed in the gap and hence the portion of the flux flowing through the oxide recording surface is reversed. If the flux reversal is instantaneous in comparison to the motion of the diskette, it can be seen that the portion of the diskette surface that just passed under the gap is magnetized in one direction while the portion under the gap is magnetized in the opposite direction. This flux reversal represents a bit. See Figure 20.

**7.4** During a read operation, a bit is read when the flux direction in the ring is reversed as a result of a flux reversal on the diskette surface. The gap first passes over an area that is magnetized in one direction, and a constant flux flows through the ring and coil. The coil registers no output voltage at this point. When a recorded bit passes under the gap, the flux flowing through the ring and coil will make a 180° reversal. This means that the flux reversal in the coil will cause a voltage output pulse. See Figure 21.

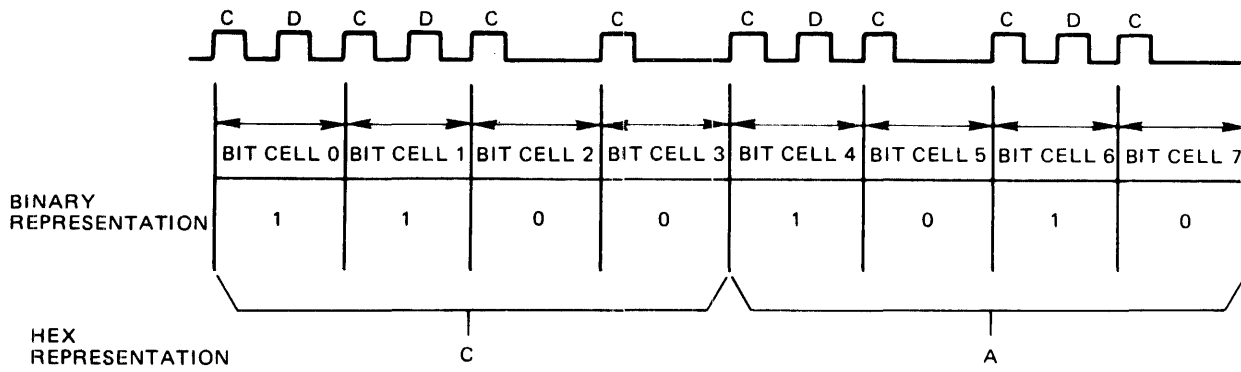

FIGURE 18. BIT CELL

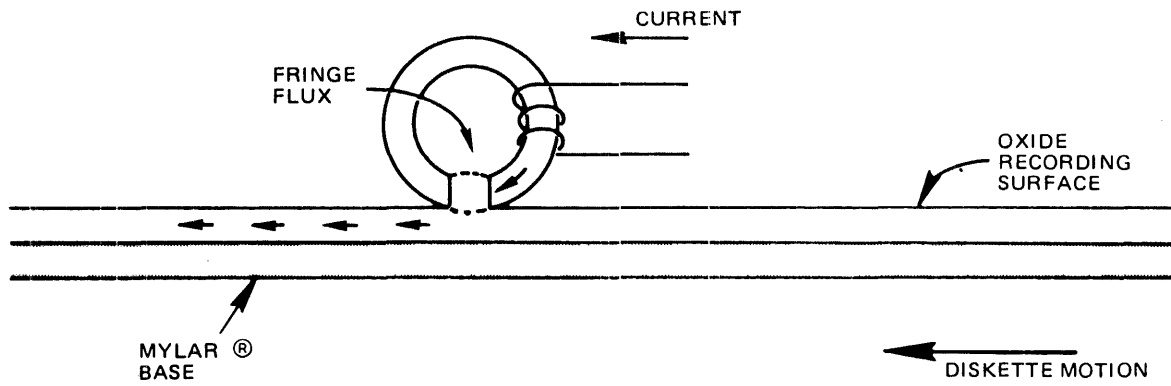

FIGURE 19. BASIC READ/WRITE HEAD

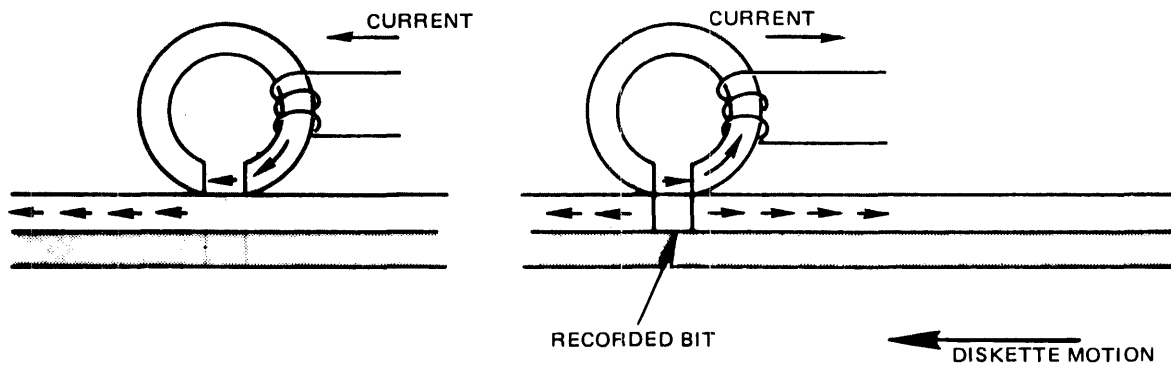

FIGURE 20. RECORDED BIT

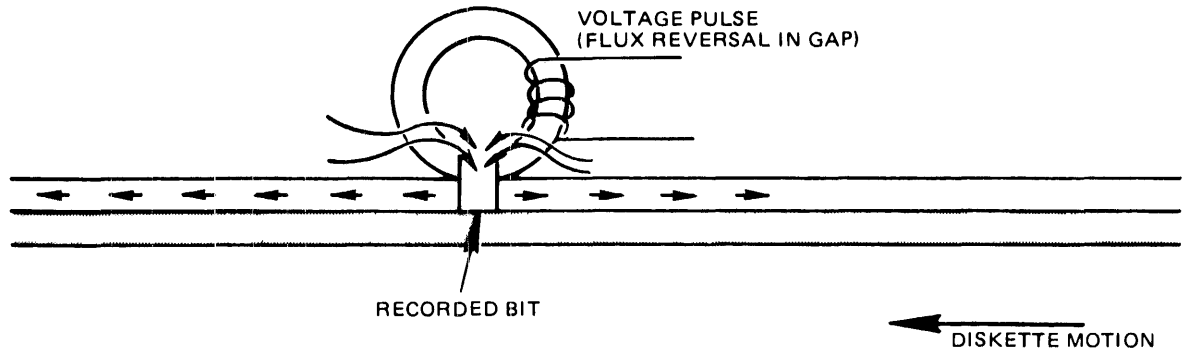

FIGURE 21. READING A BIT

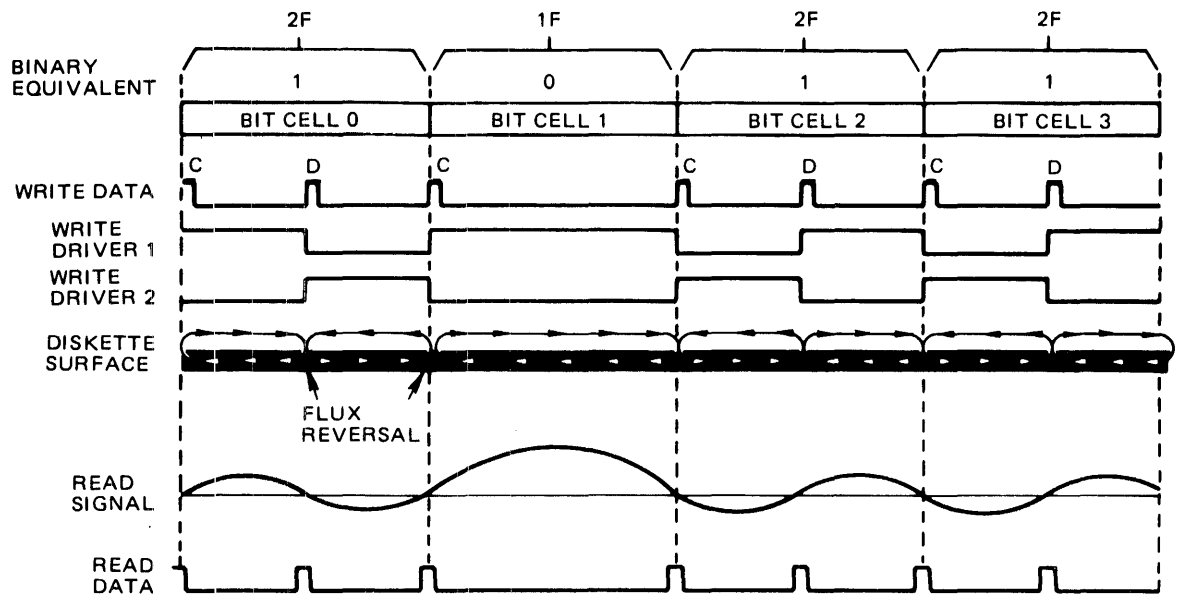

FIGURE 22. 1F AND 2F RECORDING FLUX AND PULSE RELATIONSHIP

## 8.0 READ/WRITE HEAD

- The read/write head contains three coils.
- When writing, the head erases the outer edges of the track to insure data recorded will not exceed the .012 track width.
- The head is ceramic.

**8.1** The read/write head contains three coils. Two read-write coils are wound on a single core, center tapped and one erase coil is wound on a yoke that spans the track being written. The read-write and erase coils are connected as shown on Figure 23.

**8.2** On a write operation, the erase coil is energized. This causes the outer edges of the track to be trim erased so as the track being recorded will not exceed the .012" track width. The straddle erasing allows for minor deviations in read/write head current so as one track is recorded, it will not "splash over" to adjacent tracks.

**8.3** Each bit written will be directed to alternate read/write coils, thus causing a change in the direction of current flow through the read/write head. This will cause a change in the flux pattern for each bit. The current through either of the read/write coils will cause the old data to be erased as new data is recorded.

**8.4** On a read operation, as the direction of flux changes on the diskette surface as it passes under the gap, current will be induced into one of the windings of the read/write head. This will result in a voltage output pulse. When the next data bit passes under the gap, another flux change in the recording surface takes place. This will cause current to be induced in the other coil causing another voltage output pulse of the opposite polarity.

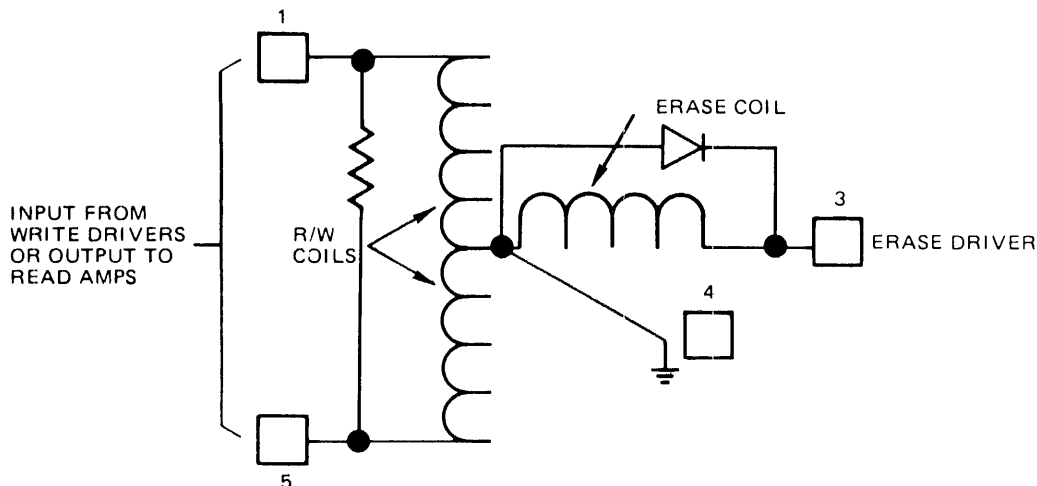

FIGURE 23. READ/WRITE HEAD

### 9.0 WRITE CIRCUIT OPERATION (FIGURE 24)

- The Write Data Trigger flips with each pulse on the Write Data line.
- The Write Data Trigger alternately drives one or the other of the Write Drivers.
- Write Gate allows write current to flow to the Write Driver circuits if diskette is not write protected.
- Write Current sensed allows Erase Coil current.

**9.1** Write data pulses (clock & data bits) are supplied by the using system. The Write Trigger “flips” with each pulse. The Q and Q outputs are fed to alternate Write Drivers.

**9.2** Write Gate, and not Write Protect, are anded together and will cause write current to flow to the Write Driver circuits, which in turn causes the Center Tap Switch to close and erase current to flow.

**9.3** The output of one of the Write Drivers allows write current to flow through one half of the read/write coil. When the Write Trigger “flips”, the other Write Driver provides write current to the other half of the read/write coil.

**9.4** The removal of Write Gate causes the Turn Off Degauss Delay circuit to slowly reduce write current for 25 microseconds. During this time if Write Gate is toggled the Read/Write head will be degaussed by the decreasing write current. At the end of the delay the Center Tap Switch opens and the Erase Current Source is turned off.

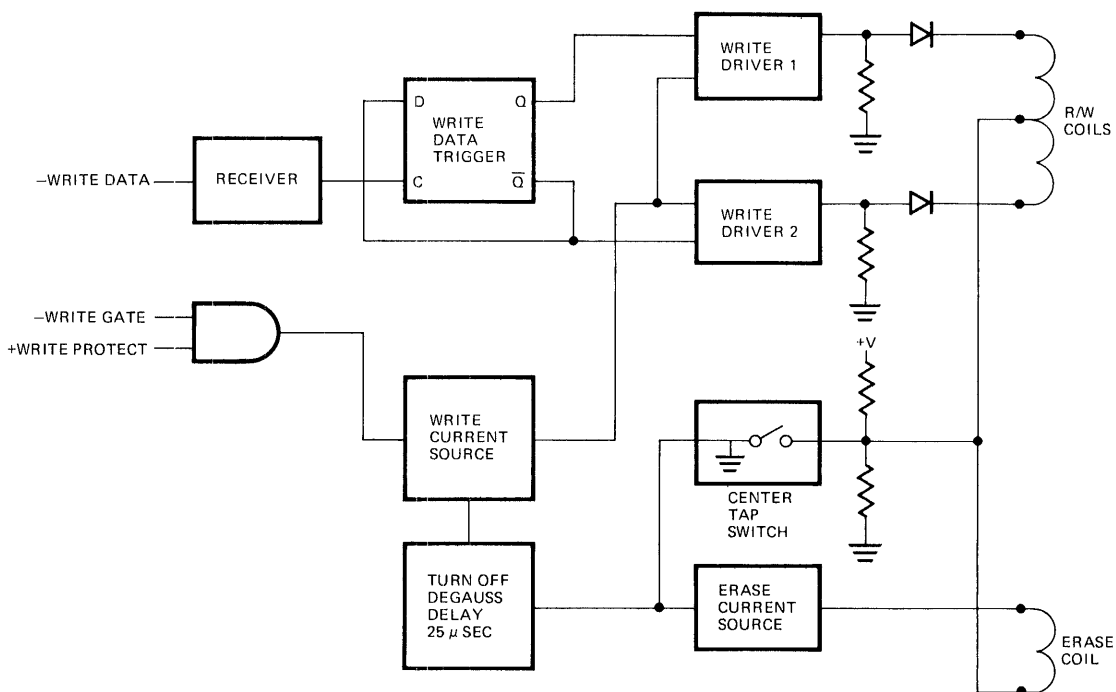

FIGURE 24. WRITE CIRCUIT FUNCTIONAL DIAGRAM

## 10.0 READ CIRCUIT OPERATION (FIGURE 25)

- Duration of all read operations is under control of the using system.
- When the head is loaded, the read signal amplitude becomes active and is fed to the amplifier.
- As long as the head is loaded, the drive is selected and write gate is not active, the read signal is amplified and shaped, the square wave signals are sent to the interface as read data.

**10.1** When the using system requires data from the diskette drive, the using system must first load the head. With loading of the head and write gate being inactive, the read signal is fed to the amplifier section of the read circuit. After the amplification, the read signal is fed to a filter where the noise spikes are removed. The read signal is then fed to the differential amplifier.

**10.2** Since a pulse occurs at least once every  $8 \mu\text{s}$  and when data bits are present once every  $4 \mu\text{s}$ , the frequency of the read data varies. The read signal amplitude decreases as the frequency increases. Note the signals on Figure 25. The differential amplifier will amplify the read signals to even levels and make square waves out of the read signals (sine waves).

The drive has no data separator only a pulse standardizer for the read data signal.

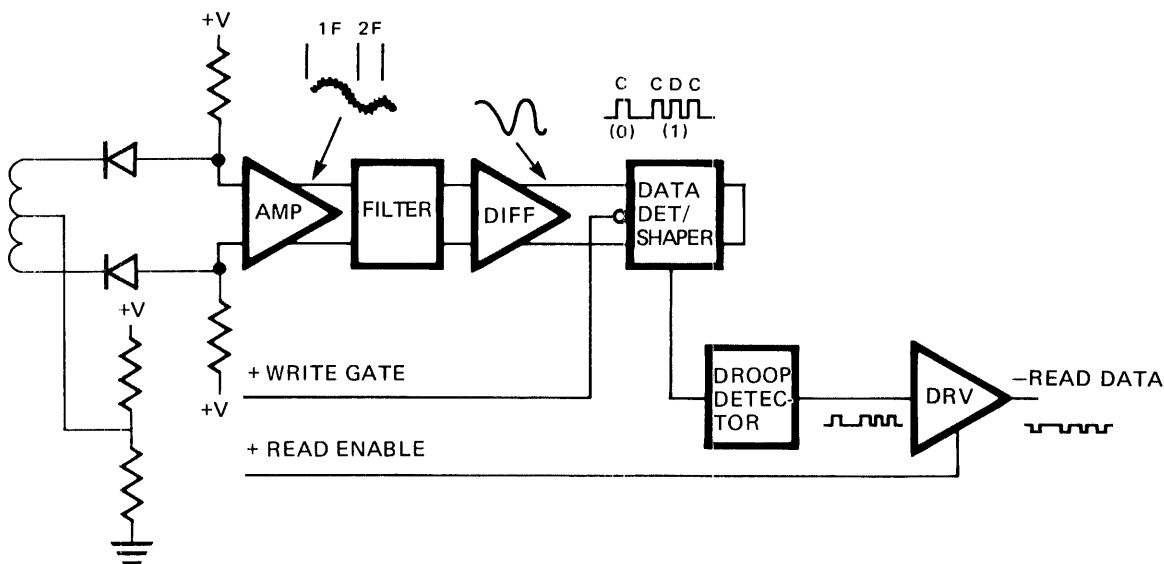

FIGURE 25. READ CIRCUIT FUNCTIONAL DIAGRAM



## 11.0 WRITE PROTECT

The SA 400 uses a write protect micro switch which is activated when a Diskette with a write protect label is inserted.

The micro switch is a normally closed switch to ground. When the switch is opened it applies a positive level to the output driver if output enable is active. This gives a low level to the interface pin 28. The signal and write protect prevents write gate from turning on write current. If the "WP" trace is cut, writing to the diskette is inhibited unless a Write Protect label is installed over the notch. Figure 26 shows the logic required.

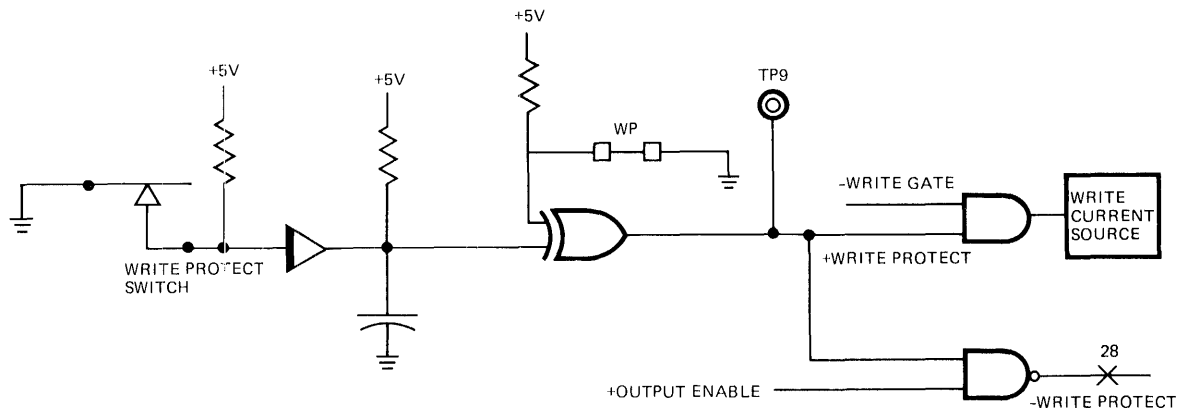

FIGURE 26. WRITE PROTECT FUNCTIONAL DIAGRAM

## 12.0 INTERFACE

The electrical interface between the SA 400 drive and the host system is via two connectors. The first connector, J1, provides the signal interface; the second connector, J2, provides the DC power. Frame ground is connected via a faston connector located near the motor control PCB.

### 12.1 J1/P1 CONNECTOR

Connection to J1 is through a 34 pin PCB edge card connector. The pins are numbered 1 through 34 with the even numbered pins on the component side of the PCB and the odd numbered pins on the non-component side. Pin 2 is located on the end of the PCB connector closest to the corner and is labeled 2. A key slot is provided between pins 4 and 6 for optional connector keying. Refer to Figure 28.

### 12.2 D.C. POWER

D.C. power to the drive is via connector P2/J2 which is located on the non-component side of the

drive PCB near the spindle drive motor. The drive uses 2 voltages. Figure 27 outlines the voltage and current requirements.

### 12.3 INPUT OUTPUT LINES

There are four (4) output lines from the SA 400. The output signals are driven with an open collector output stage capable of sinking a maximum of 40 ma at a logical zero level or true state with a maximum voltage of 0.4V measured at the driver. When the line driver is in a logical one or false state the driver is off and the collector current is a maximum of 250 microamperes.

There are 8 input lines to the SA 400. These input lines have the following electrical specifications. Reference Figure for the recommended circuit.

True = Logical zero =  $V_{in} \pm 0.0V$  to  $+0.4V$   
@ $I_{in} = 40$  ma (max)

False = Logical one =  $V_{in} +2.5V$  to  $+5.25V$   
@ $I_{in} = 0$  ma (open)

Input Impedance = 150 ohms

P2 PIN	DC VOLTAGE	TOLERANCE	CURRENT	MAX RIPPLE (ptop)
1	+12 VDC	$\pm 0.6$ VDC	* 1.80A MAX .90A TYP	100 mV
2	+12 Return			
3	+ 5 Return			
4	+ 5 VDC	$\pm 0.25$ VDC	.70A MAX .50A TYP	50 mV

\*The 12 VDC current is composed of three components; head load current, diskette drive motor current, and PCB functions. Each of these components has the following contribution to the 12 VDC current requirements.

1. PCB functions (Drive "Standby" current)—0.4A TYP; 0.5A AMX
2. Head Load (Drive Selected)—0.15A TYP; 0.2A MAX
3. Drive Motor: Start (for 1 sec. max.)—1.0A TYP; 1.1A MAX  
Running 0.35A TYP; 1.1A MAX (Motor Stalled)

FIGURE 27. D.C. POWER

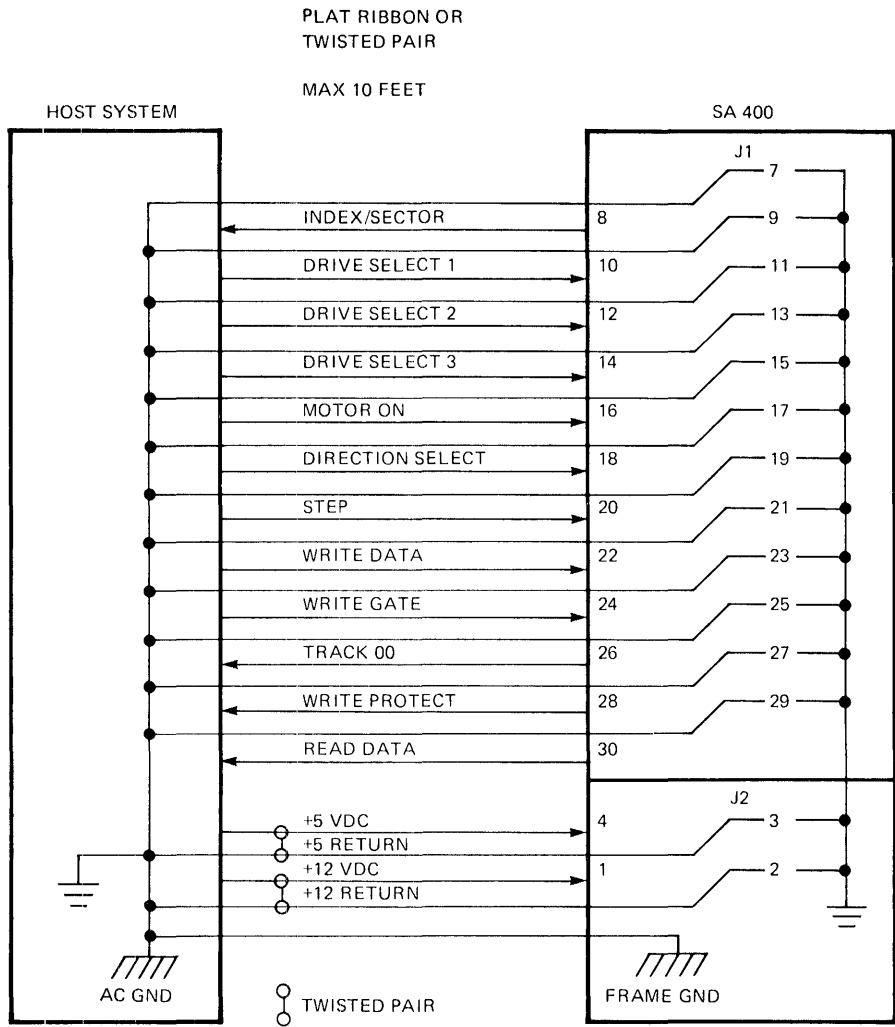

FIGURE 28. SA400 INTERFACE CONNECTIONS

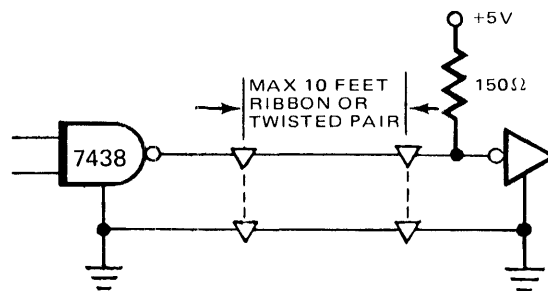

FIGURE 29. INTERFACE SIGNAL DRIVER/RECEIVER

**Section 2**

# Table of Contents

---

2.1	Maintenance Features . . . . .	1
2.1.1	Alignment Diskette . . . . .	1
2.1.2	Exerciser . . . . .	1
2.1.3	Special Tools . . . . .	2
2.2	Diagnostic Techniques . . . . .	2
2.2.1	Introduction . . . . .	2
2.2.2	“Soft Error” Detection and Correction . . . . .	2
2.2.3	Write Error . . . . .	2
2.2.4	Read Error . . . . .	2
2.2.5	Seek Error . . . . .	2
2.2.6	Interchange Errors . . . . .	2
2.2.7	Test Points SA400 . . . . .	3
2.3	Preventative Maintenance . . . . .	3
2.4	Removals and Adjustments . . . . .	3
2.4.1	Face Plate: Removal and Installation . . . . .	3
2.4.2	Drive Motor Assembly: Removal and Installation (includes the motor and PCB) . . . . .	4
2.4.3	Stepper Motor and Actuator Cam . . . . .	4
2.4.4	Head and Carriage Assembly . . . . .	4
2.4.4.1	Read/Write Head Load Button: Removal and Installation . . . . .	4
2.4.5	Spindle Hub and Pulley/Assembly . . . . .	4
2.4.6	Clamp Hub Removal . . . . .	5
2.4.7	Hub Frame Assembly Removal . . . . .	5
2.4.7.1	Hub Frame Assembly Installation and Adjustment . . . . .	5
2.4.8	Write Protect Switch Removal . . . . .	5
2.4.9	Index Detector Assembly Removal . . . . .	5
2.4.10	Index LED Removal . . . . .	6
2.4.11	Track Zero Switch Removal . . . . .	6
2.4.12	Head Amplitude Check . . . . .	6
2.4.13	Motor Speed Adjustment . . . . .	6
2.4.13.1	Motor Speed Adjustment (using a frequency counter) . . . . .	6
2.4.14	Read/Write Head Load Button Adjustment . . . . .	7
2.4.15	Track Zero Switch Adjustment . . . . .	7
2.4.16	Carriage Limiter . . . . .	7
2.4.17	Index/Sector Timing Adjustment . . . . .	8
2.4.18	Head/Radial Alignment . . . . .	8

2.4.19 Write Protect Switch Adjustment . . . . .	10
2.4.20 Head Load Bail Adjustment . . . . .	10
2.4.21 Read/Write Head Cleaning Procedure . . . . .	10
Physical Locations . . . . .	11
PCB Component Locations . . . . .	15
Logic Manual . . . . .	19
Schematics . . . . .	25

## List of Illustrations

---

1. Test Point Locations . . . . .	3
2. Head Load Button Replacement . . . . .	4
3. Hub Frame Adjustment . . . . .	5
4. Motor Speed Adjustment . . . . .	6
5. Track Zero Position . . . . .	7
5.1 Track Zero Switch Adjustment . . . . .	7
6. Carriage Limiter Adjustment . . . . .	7
7. Carriage Limiter Clearance . . . . .	8
8. Index Detector Adjustment . . . . .	8
9. SA400 Service Position . . . . .	8
10. Index Timing . . . . .	9
11. Head Radial Alignment . . . . .	9
12. Head Radial Alignment . . . . .	9
13. Write Protect Switch Adjustment . . . . .	10
14. Head Load Bail Adjustment . . . . .	10

## 2.1 MAINTENANCE FEATURES

### 2.1.1 Alignment Diskette

The SA 124 alignment diskette is used for alignment of the SA 400. The following adjustments and checks can be made using the SA 124.

1. Read/write head radial adjustment using track 16.
2. Index photo detector alignment using track 01.
3. Track 00 is recorded with a 125 KHz signal (2F). This track is used to tell if the head is positioned over track zero when the track zero indication is true.
4. Track 34 has a 125 KHz signal (2F) recorded on it and is used to tell if the head is positioned over track 34 and for reference purposes.

Caution should be used in order not to destroy pre-recorded alignment tracks. These tracks are 00, 01, 15, 16, 17, & 34. The write protect tab should always be installed on the SA 124 to prevent accidental writing on the SA 124, or if the Write Protect option is utilized, remove the Write Protect tab.

### 2.1.2 Exerciser

The exerciser is a 800 exerciser with a special cable set. The exerciser PCB can be used in a stand alone mode or it can be built into a test station or used in a tester for Field Service.

The exerciser will enable the user to make all adjustments and check outs required on the SA 400 Mini Diskette drive.

The exerciser has no intelligent data handling capabilities but can write a 2F 125KHz signal which is the recording frequency used for amplitude check in the SA 400 drive. The exerciser can start and stop the drive motor, and enable read in the SA 400 to allow checking for proper read back signals.

### 2.1.3 Special Tools

The following special tools are available for performing maintenance on the SA 400.

Description	Part Number
Alignment Diskette	SA 124
Exerciser	54157
Head Cable Extender	54143

## 2.2 DIAGNOSTIC TECHNIQUES

### 2.2.1 Introduction

Incorrect operating procedures, faulty programming, damaged diskettes, and "soft errors" created by airborne contaminants, random electrical noise, and other external causes can produce errors falsely attributed to drive failure or misadjustment. Unless visual inspection of the drive discloses an obvious misalignment or broken part, attempt to repeat the fault with the original diskette, then attempt to duplicate fault on second diskette.

### 2.2.2 "Soft Error" Detection and Correction

Soft errors are usually caused by:

1. Airborne contaminants that pass between the read/write head and the disk. Usually these contaminants can be removed by the cartridge self-cleaning wiper.
2. Random electrical noise that usually lasts for a few  $\mu$  seconds.
3. Small defects in the written data and/or track not detected during the write operation that may cause a soft error during a read.
4. Worn or defective load pad.
5. Improper grounding of the power supply, drive and/or host system. Refer to the SA 400 OEM manual for proper grounding requirements.
6. Improper motor speed.

The following procedures are recommended to recover from the above mentioned soft errors:

1. Reread the track ten (10) times or until such time as the data is recovered.
2. If data is not recovered after using step 1, access the head to the adjacent track in the same direction previously moved, then return to the desired track.
3. Repeat step 1.
4. If data is not recovered, the error is not recoverable.

### 2.2.3 Write Error

In an error occurs during a write operation, it will be detected on the next revolution by doing a read operation, commonly called a "write check". To

correct the error, another write and check operation must be done. If the write operation is not successful after ten (10) attempts have been made, a read operation should be attempted on another track to determine if the media or the drive is failing. If the error still persists, the diskette should be replaced and the above procedure repeated. If the failure still exists, consider the drive defective. If the failure disappears, consider the original diskette defective and discard it.

### 2.2.4 Read Error

Most errors that occur will be "soft errors". In these cases, performing an error recovery procedure will recover the data.

### 2.2.5 Seek Error

1. Stepper malfunction.
2. Carriage binds.
3. To recover from a seek error recalibrate to track 00 and perform another seek to the original track or do a read I.D. to find what track the head is on and compensate accordingly.

### 2.2.6 Interchange Errors

This error is identified to be when data written on one drive cannot be read correctly on another drive.

Probable cause and checks:

1. Head alignment reference section 2.4.18.
2. Head amplitude low. Check on both drives per section 2.4.12.
3. Motor speed out of adjustment. Check on both drives per section 2.4.13.
4. Mis-clamping of the diskette caused by center hole damage. Replace the diskette and check the clamp hub.
5. If hard sectored check the index timing adjustment section 2.4.17.
6. If hard sectored insure the recommended sector format is being followed. reference the SA 400 OEM manual for proper format requirements.



### 2.2.7 Test Points SA 400

Reference figure 1.

- T.P.
1. Read Data Signal
  2. Read Data Signal
  3. Read Data (Differentiated)
  4. Read Data (Differentiated)
  5. Signal Ground
  6. + Read Data
  7. + Index
  8. - Detect Track 00
  9. + Write Protect
  10. Ground
  11. - Head Load
  12. + Gated Step Pulses
  13. - Motor On

### 2.3 PREVENTIVE MAINTENANCE

Preventative maintenance is not required on the SA 400 minifloppy under normal usage.

### 2.4 REMOVALS AND ADJUSTMENTS

#### 2.4.1 Face Plate: Removal and Installation

- a. Open the door.
- b. Remove the mounting screw on each side of the faceplate. Pull the face plate forward and away from the drive casting.
- c. No re-adjustment is required after replacement.

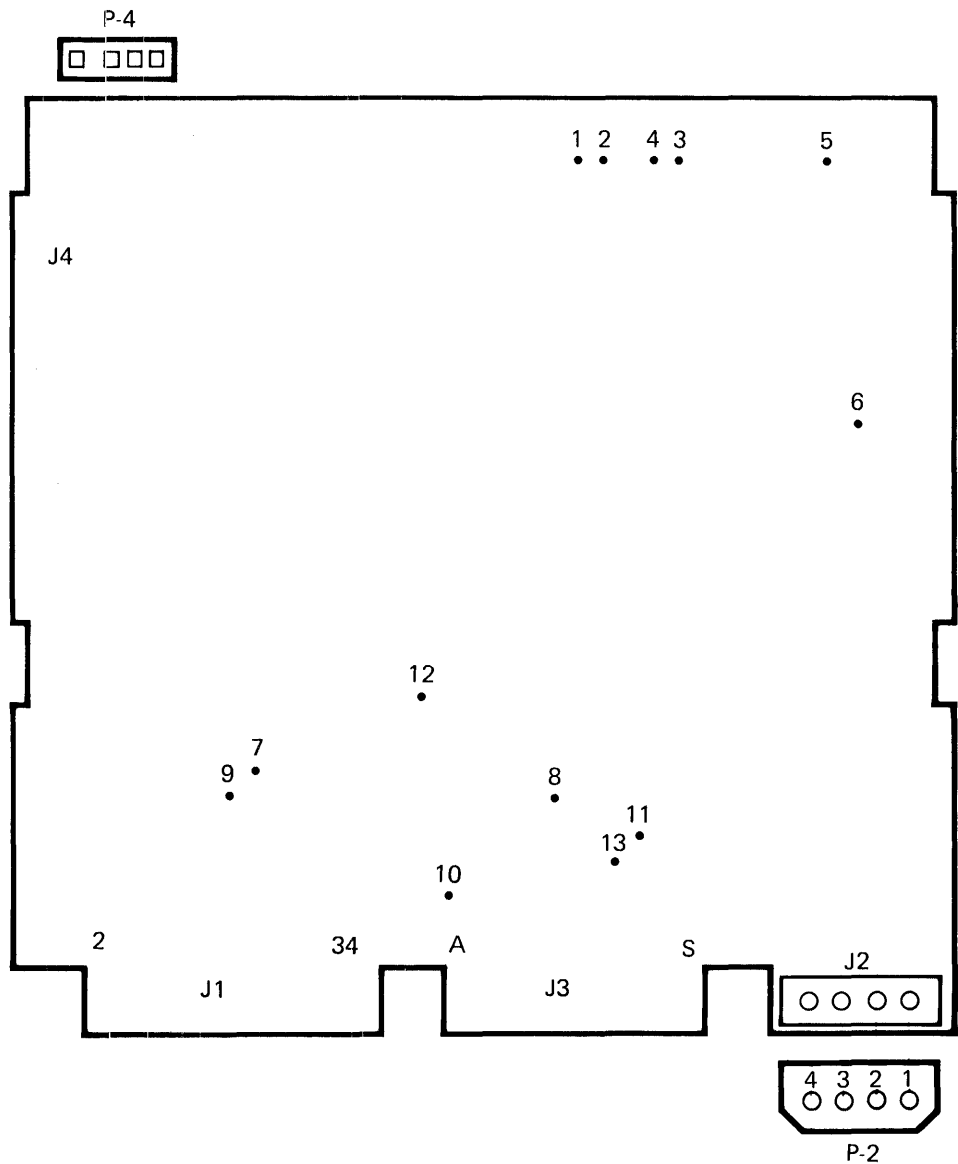

FIGURE 1. TEST POINT LOCATIONS

#### 2.4.2 Drive Motor Assembly: Removal and Installation (includes the motor and PCB)

Note: For ease of replacement it is recommended to replace the motor and PCB as an entire assembly.

- a. Remove drive belt.
- b. Disconnect connector P-3 from drive PCB and extract pins K (org) 13 (brn) and 14 (blk).
- c. Remove drive PCB.
- d. Remove the drive motor PCB and drive motor as an assembly by removing their respective mounting screws.
- e. To re-install, reverse the above procedure insuring the PCB spacers and faston tab are in place.
- f. Motor speed must be adjusted as per section 2.4.13.

#### 2.4.3 Stepper Motor and Acuator Cam

These assemblies are not field replaceable.

#### 2.4.4 Head and Carriage Assembly

- a. Remove the drive PCB and disconnect the head connector from the PCB.
- b. Unclamp the head cable from the drive.
- c. Remove the guide rod nearest the read/write head.
- d. Pivot the carriage away from the cam and off of the lower guide rod.
- e. To re-install, reverse the above.

**IMPORTANT:** Insure that after installing the head cable there is enough slack to allow the carriage to go to track zero.

- f. Readjust the carriage limiter if a new carriage is installed. Reference section 2.4.16.
- g. Head alignment should not be required but if interchange problems exist check and adjust head alignment per section 2.4.18.

#### 2.4.4.1 Read/Write Head Load Button: Removal and Installation

- a. Remove drive PCB.
- b. To remove the old button, hold the load arm out away from head, squeeze the locking tabs together with a pair of needle nose pliers and press forward.
- c. To install load button, press the button into the arm, from the head side, and it will snap into place. Reference figure 2.
- d. Adjust according to section 2.4.14.

#### 2.4.5 Spindle Hub and Pulley/Assembly

These assemblies are not field replaceable.

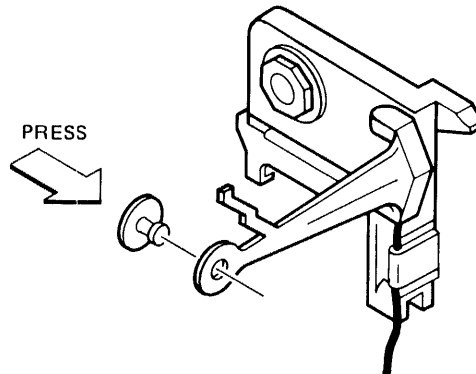

FIGURE 2. HEAD LOAD BUTTON REPLACEMENT

#### 2.4.6 Clamp Hub Removal

- a. Remove face plate, Reference section 2.4.1.
- b. Remove the drive PCB.
- c. Remove the E-ring from the hub shaft. The entire assembly can now be removed from the hub frame. Care should be taken not to overstress the hub frame mounting pivot springs.
- d. To re-install: Place the hub clamp with spacer and spring in place onto the spindle hub. (The large end of the spring is placed against the hub frame).
- e. Press the hub frame down towards the spindle until the hub shaft protrudes through its mounting hole in the hub frame.
- f. Install the E-ring onto the hub shaft.
- g. Re-install the face plate. Re-adjustment is not required.

#### 2.4.7 Hub Frame Assembly Removal

Removal of this assembly is not normally required or recommended. The only time removal would be required in the field is to replace the entire assembly.

- a. Remove the drive PCB.
- b. Remove the 2 mounting screws that hold the pivot springs to the casting.
- c. The hub frame assembly can now be lifted clear of the casting.

##### 2.4.7.1 Hub Frame Assembly Installation and Adjustment

- a. Put the hub frame onto drive and lightly tighten mounting screws removed in Step 2 of Removal Procedures.

- b. Latch the hub frame closed.
- c. Position the hub frame until the hub shaft is centered in its mounting hole in the hub frame Reference figure 3. Now tighten the mounting screws for the hub frame pivot springs.
- d. Check that the door latch assembly does not bind in the face plate. If binding occurs loosen the door latch mounting screws and reposition until it is free of binds.
- e. Reinstall the drive PCB.
- f. Check and readjust the index timing if drive is used in hard sectored applications. Refer to section 2.4.17.

#### 2.4.8 Write Protect Switch Removal

- a. Remove the two mounting screws for the switch.
- b. Unsolder the brown wire from the C terminal and the black wire from N/C on the switch.
- c. After reinstallation adjust per section 2.4.19.

#### 2.4.9 Index Detector Assembly Removal

- a. Remove drive PCB.
- b. From connector P-3 extract pins from 5 (orange) and E (red).
- c. Remove the detector mounting screw from the hub frame. This will free the detector.
- d. When installing a new assembly, insure the detector mounting block is flush against the side of the hub frame. Reference figure 3.
- e. Re-adjust the index timing per section 2.4.17.

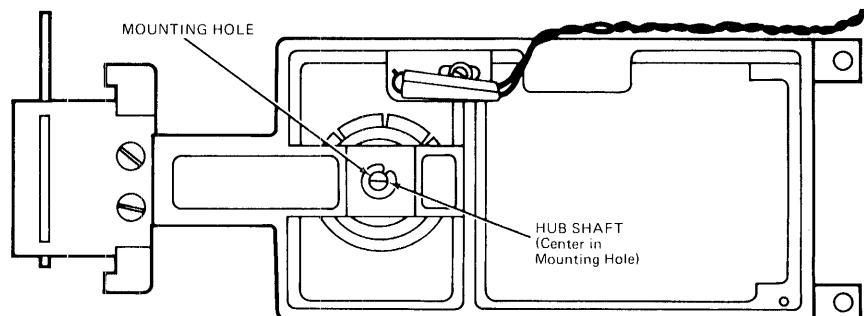

FIGURE 3. HUB FRAME ADJUSTMENT

#### 2.4.10 Index LED Removal

- a. Remove the drive PCB.
- b. From connector P-3 extract the pins from 8 (blue) and J (purple).
- c. Remove the platen from the base casting that the LED is mounted to.
- d. Squeeze the led mounting block locking tabs together and press the assembly out of the mounting hole in the platen.
- e. To re-install, reverse the removal procedure
- f. When remounting the platen, insure it is flush with the machine surface on the casting. Position it laterally so a diskette can be inserted without binding when the door is closed.
- g. Re-adjust the index timing per section 2.4.17 if hard sectored.

#### 2.4.11 Track Zero Switch Removal

- a. Remove the drive PCB.
- b. The switch is removed by removing its two mounting screws.
- c. Un-solder the wires N/C (white) N/O (yellow) and com (green).
- d. To reinstall, reverse the above procedure.
- e. Readjust the switch per section 2.4.15.

#### 2.4.12 Head Amplitude Check

These checks are only valid when writing and reading back as described below. If the amplitude is below the minimum specified, the load pad should be replaced and the head should be cleaned if necessary (Reference section 2.4.21) before re-writing and re-checking. Insure the diskette used for this check is not "worn" or otherwise shows evidence of damage on either the load pad or the head side.

- a. Install good media.
- b. Start the motor.
- c. Select the drive and step to track 34.
- d. Sync the oscilloscope external on TP 7 (+ Index), connect one probe to TP-2 and one to TP-1, on the drive PCB. Ground the probes to the PCB, add and invert one input. Set volts per division to 50mv and time base to 20 M seconds per division.

- e. Write the entire track with all one's.
- f. The average minimum read back amplitude, peak to peak, should be 80 millivolts.

If a new load pad does not bring the amplitude to the minimum level try the following:

1. Install a different piece of media and re-check.
2. Check motor speed section 2.4.13.
3. Make sure you are getting an output from both TP-1 and TP-2. Check with the scope in the chop mode. If the probes are OK and still one TP has no output or has less output than the other TP replace the PCB.
4. If 1, 2, & 3 are OK the head and carriage assembly will require replacement. Refer to section 2.4.4.

#### 2.4.13 Motor Speed Adjustment

- a. Install a diskette, start the motor and load the head. Step to Track 16.
- b. Turn the pot R-12 located on the motor control PCB until the dark lines on the spindle pulley appear motionless. For 60 HZ use the outside ring of lines for 50 HZ observe the inside ring. Reference figure 4.

NOTE: This adjustment can be made only in an area where there is fluorescent lighting. Otherwise refer to 2.4.13.1.

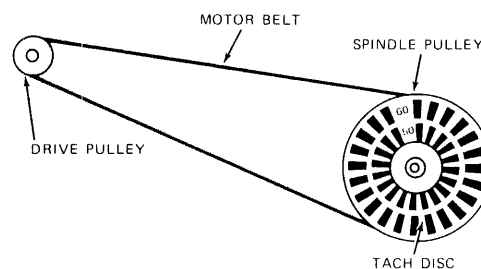

FIGURE 4. MOTOR SPEED ADJUSTMENT

#### 2.4.13.1 Motor Speed Adjustment (using a frequency counter)

- a. Install a SA104 or SA124 diskette, start the motor and load the head, step to Track 16.
- b. Connect the frequency counter input to T.P. 7 (+ Index) on the drive PCB.
- c. Adjust pot R-12 located on the motor control PCB for 200 HZ  $\pm 0.2$  HZ.

#### 2.4.14 Read/Write Head Load Button Adjustment

- Insert SA124 diskette or any diskette with data on track 34.
- Connect oscilloscope to TP 1 and 2, added differentially and sync external positive on TP 7 (+ Index).
- Start the motor.
- Select the drive and step carriage to track 34.
- Observing read signal on oscilloscope, rotate the load button counterclockwise in small increments (10°) until maximum amplitude is obtained.

#### 2.4.15 Track Zero Switch Adjustment

- Remove the PCB from the drive, disconnect the head cable but leave the interface and drive connector installed.
- Rotate head cam actuator until the cam follower is opposite the track zero dimple on the cam. Reference figure 5.

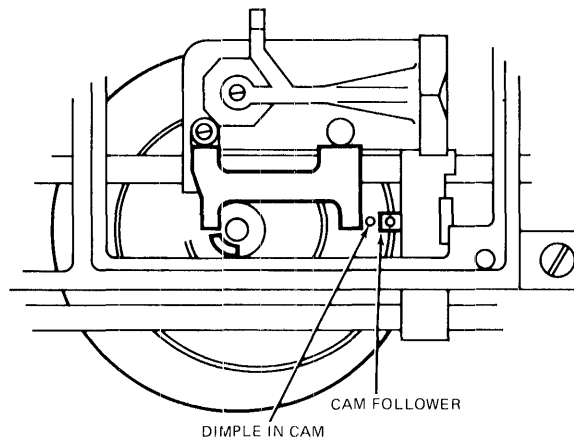

FIGURE 5. TRACK ZERO POSITION

- Adjust the switch so it just makes by moving its mounting bracket.

NOTE: When making switch adjustments insure that the bracket is registered against the casting and the activator is located on the 45° angled portion on the rear of the carriage. Refer to figure 5.1.

- Power up the drive being careful not to short out the PCB, and select the drive. This will energize phase A in the stepper motor. The dimple should remain within  $\pm .050$  of the cam follower and the switch should not break.

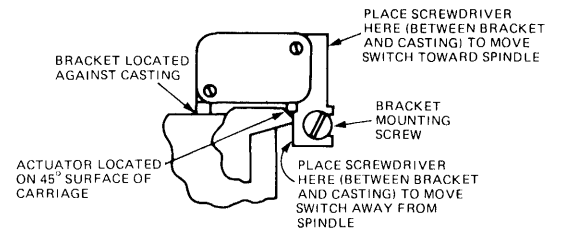

FIGURE 5.1. TRACK ZERO SWITCH ADJUSTMENT

- Step to track 1 T.P. 8 should go high. If not readjust the microswitch.
- Step to track 00 T.P. 8 should go low.
- If not readjust the microswitch.
- To check the adjustment:
  - Step to track 00 T.P. 8 should be low.
  - Step to track 00 T.P. 8 should be low.
  - Step to track 2 T.P. 8 should remain high.

#### 2.4.16 Carriage Limiter

- Unplug the head cable and remove the PCB from the drive leaving the interface and PCB connector installed.
- Step to track zero, leave the drive selected.
- Position the stop until it is flush with stop post (old style) or in the slot (new style) on the carriage assembly. Reference figure 6. Adjust the track zero carriage limiter horizontally and vertically until there is  $.020 \pm .005$  between the stop on the acuator cam and the stepper motor shaft. Reference figure 6.

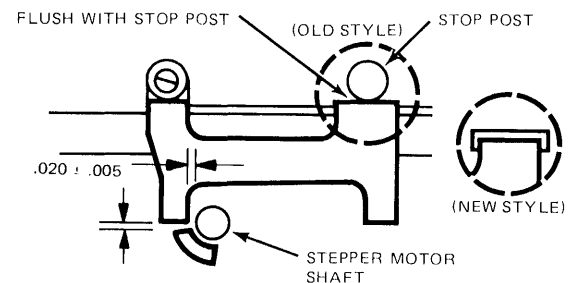

FIGURE 6. CARRIAGE LIMITER ADJUSTMENT

- d. Step to track 34 and insure there is clearance between the cam stop extension and the stepper motor shaft. Reference figure 7.
- e. Re-install the drive PCB and plug in the head cable.

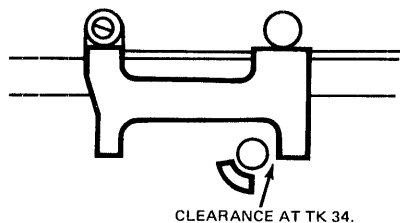

FIGURE 7. CARRIAGE LIMITER CLEARANCE

#### 2.4.17 Index/Sector Timing Adjustment

If soft sectored, using the IBM type format:

- a. Position the index detector assembly flush with the registration surface on the hub frame. Reference figure 8.
- b. Position the detector assembly in the center of its mounting slot. Tighten the mounting screw, Reference figure 8.

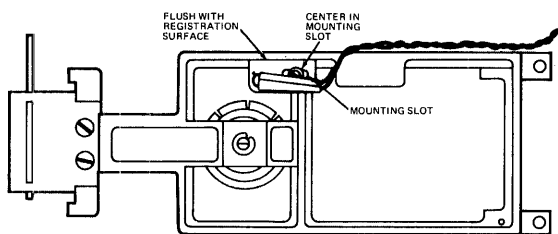

FIGURE 8. INDEX DETECTOR ADJUSTMENT

#### FOR HARD SECTORED APPLICATIONS:

- a. Remove the PCB and install the head cable extender. Leave the PCB and interface connectors installed. Reference figure 9.
- b. Insert Alignment Diskette (SA 124).
- c. Start the motor and select the drive.
- d. Step the carriage to track 01.
- e. Sync oscilloscope, external positive, on TP 7 (+ Index). Set time base to 50  $\mu$ sec/division.
- f. Connect one probe to TP 1 and the other TP 2. Ground probes to the PCB. Set the inputs to AC, add and invert one channel. Set vertical deflection to 500 MV/division.
- g. Observe the timing between the start of the sweep and the first data pulse. This should be  $200 \pm 100 \mu$ sec. If the timing is not within tolerance, continue on with the adjustment. Reference figure 10.
- h. Loosen the mounting screw in the Index Detector block until the assembly is just able to be moved.
- i. Observing the timing, adjust the detector until the timing is  $200 \pm 50 \mu$ sec. Insure that the detector assembly is against the registration surface on the hub frame.
- j. Tighten the mounting screw.
- k. Recheck the timing.

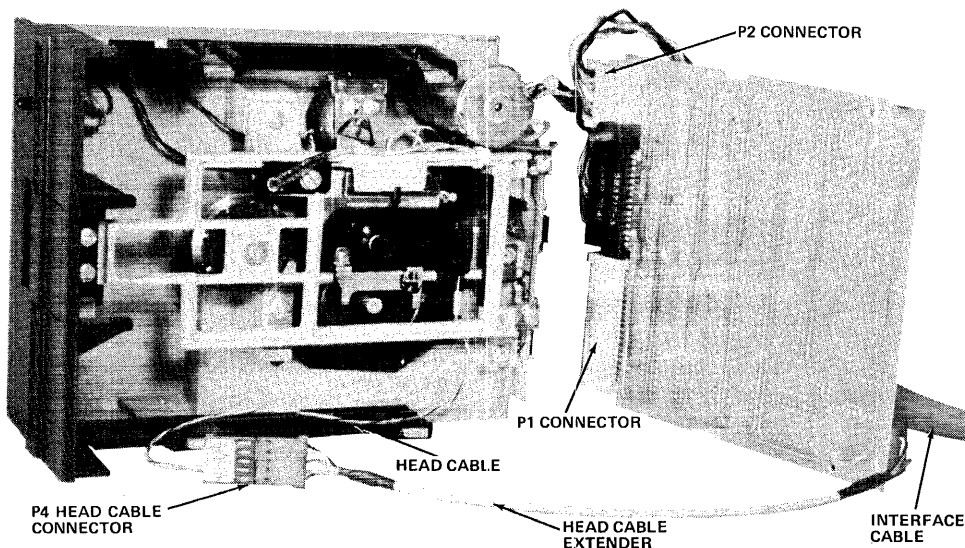

FIGURE 9. SA400 SERVICE POSITION

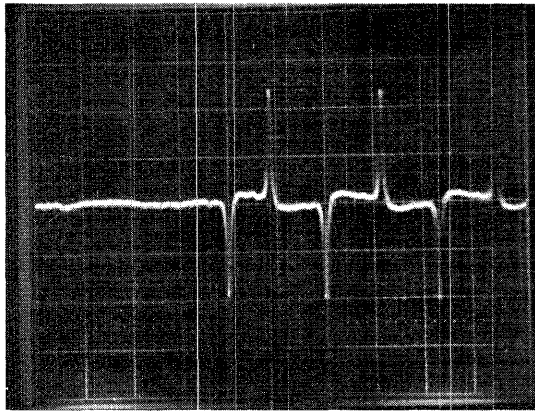

FIGURE 10. INDEX TIMING

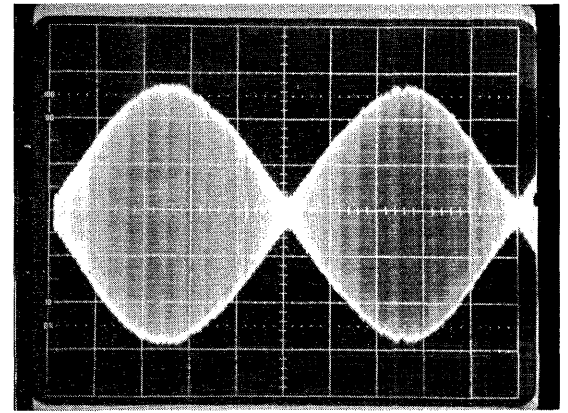

FIGURE 11. HEAD RADIAL ALIGNMENT

#### 2.4.18 Head/Radial Alignment

- a. Start the motor and select the drive.
- b. Load the SA 124 alignment diskette.
- c. Step the carriage to track 16.
- d. Sync the oscilloscope, external positive, on TP 7 (+CE Index). Set the time base to 20 Msec per division. This will display over one revolution.
- e. Connect one probe to TP 1 and the other to TP 2. Ground the probes on the PCB. Set the inputs to AC, add and invert one channel. Set the vertical deflection to 100 MV/dev.
- f. The two lobes must be within 70% amplitude of each other. If the lobes do not fall within the

specification, continue on with the procedure. Reference figure 11.

- g. Loosen the two mounting screws which mount the stepper motor to the drive casting.
- h. Rotate the stepper motor to radially move the head in or out. If the left lobe is less than 70% of the right, turn the stepper motor clockwise as viewed from the stepper motor side of the drive. If the right lobe is less than 70% of the left lobe, turn the stepper motor counterclockwise as viewed from the stepper motor side of the drive.
- i. When the lobes are of equal amplitude, tighten the motor mounting screws. Reference figure 12.

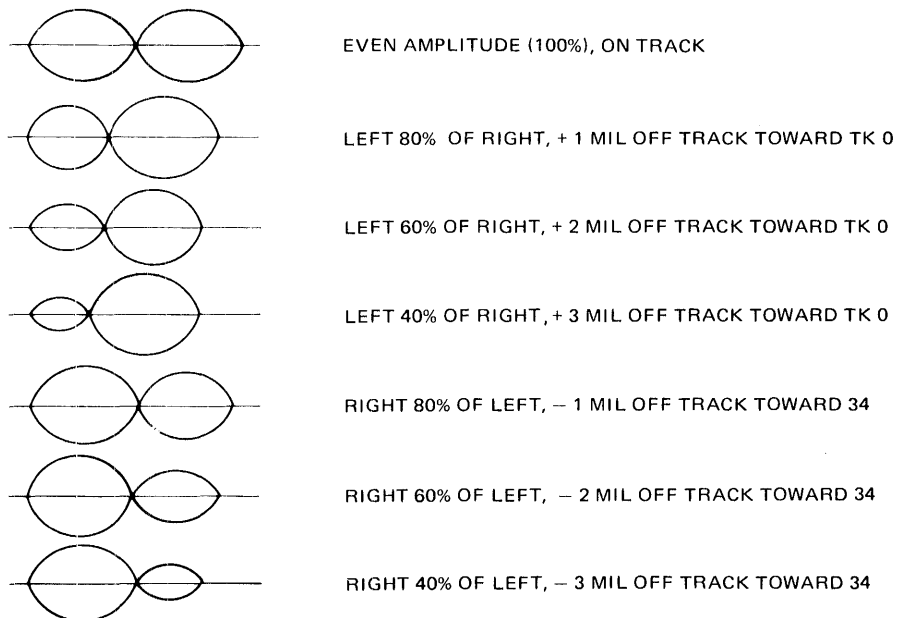

FIGURE 12. HEAD RADIAL ALIGNMENT

- j. Check the adjustment by stepping off track and returning. Check in both directions and readjust as required.
- k. Whenever the Head Radial Alignment has been adjusted, the carriage limiter and track zero switch adjustment must be checked (Section 2.4.15 & 2.4.16).

NOTE: (Alignment diskette should be at room conditions for at least twenty minutes before alignment).

**2.4.19 Write Protect Switch Adjustment**

- a. Adjust the switch so that the actuator will just transfer the switch when its point is flush  $\pm .010$  within the top of the groove in the guide rail. Reference figure 13.

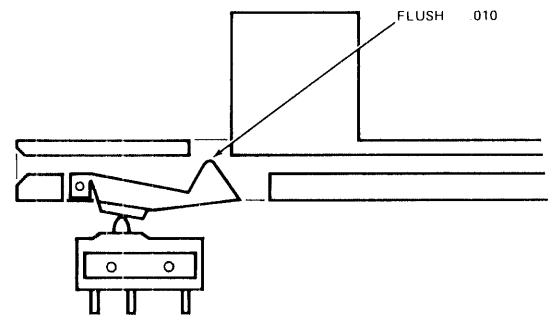

FIGURE 13. WRITE PROTECT SWITCH ADJUSTMENT

**2.4.20 Head Load Bail Adjustment**

- a. Select the drive to load the head or ground TP 11 (-Head Load) to energize the head load solenoid.
- b. Adjust the down stop screw to obtain 3/16" to 1/4" from the top flat surface of the load bail and the platen. Reference figure 14.
- c. Check for a minimal clearance of .020 between the load bail and the load arm. This check is made at track zero and track 34 with the door closed and the head loaded.

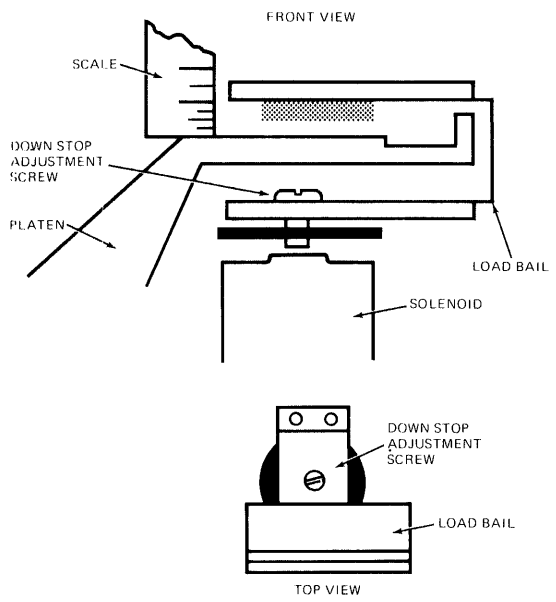

FIGURE 14. HEAD LOAD BAIL ADJUSTMENT

**2.4.21 Read/Write Head Cleaning Procedure**

The head should *ONLY* be cleaned if it has an oxide build up that is visible to the naked eye. Cleaning methods and materials other than those listed can permanently damage the head and should be avoided.

1. Lightly dampen a piece of clean lintless tissue with Isopropyl alcohol (use sparingly).
2. Lift the load arm off the head, being careful not to touch the load button.
3. Lightly wipe the head with the moistened portion of the tissue.
4. After the alcohol has evaporated, lightly polish the head with a clean dry piece of lintless tissue.
5. Lower the load arm onto the head. *Do not let it snap back.*



# Physical Locations

---

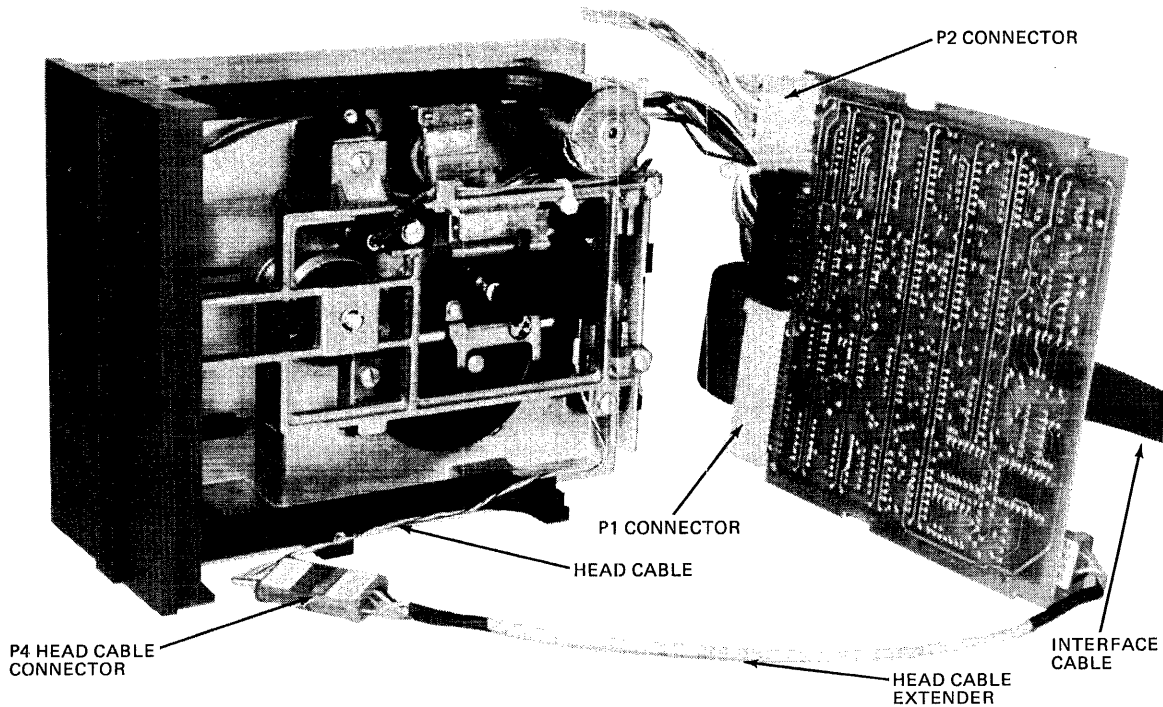
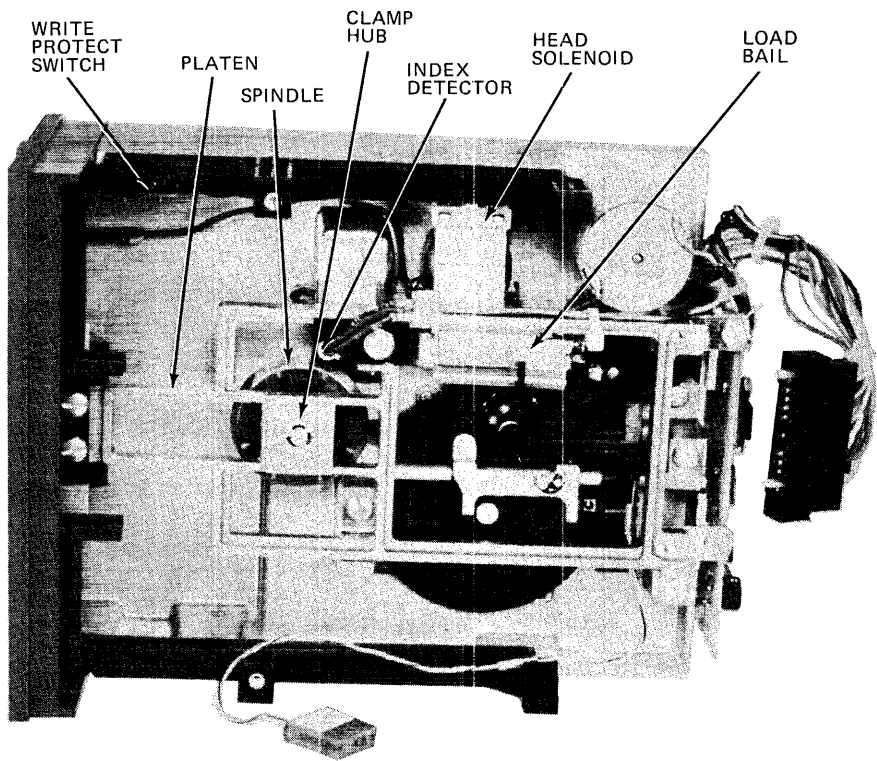

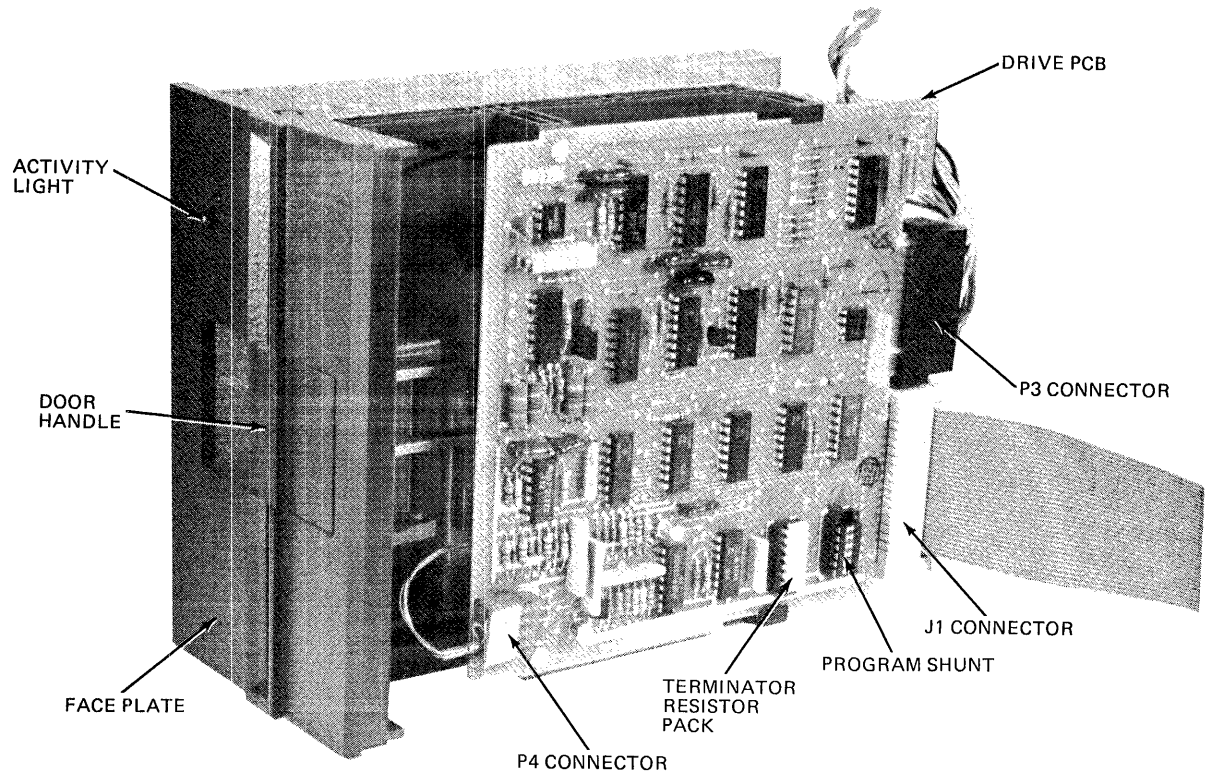
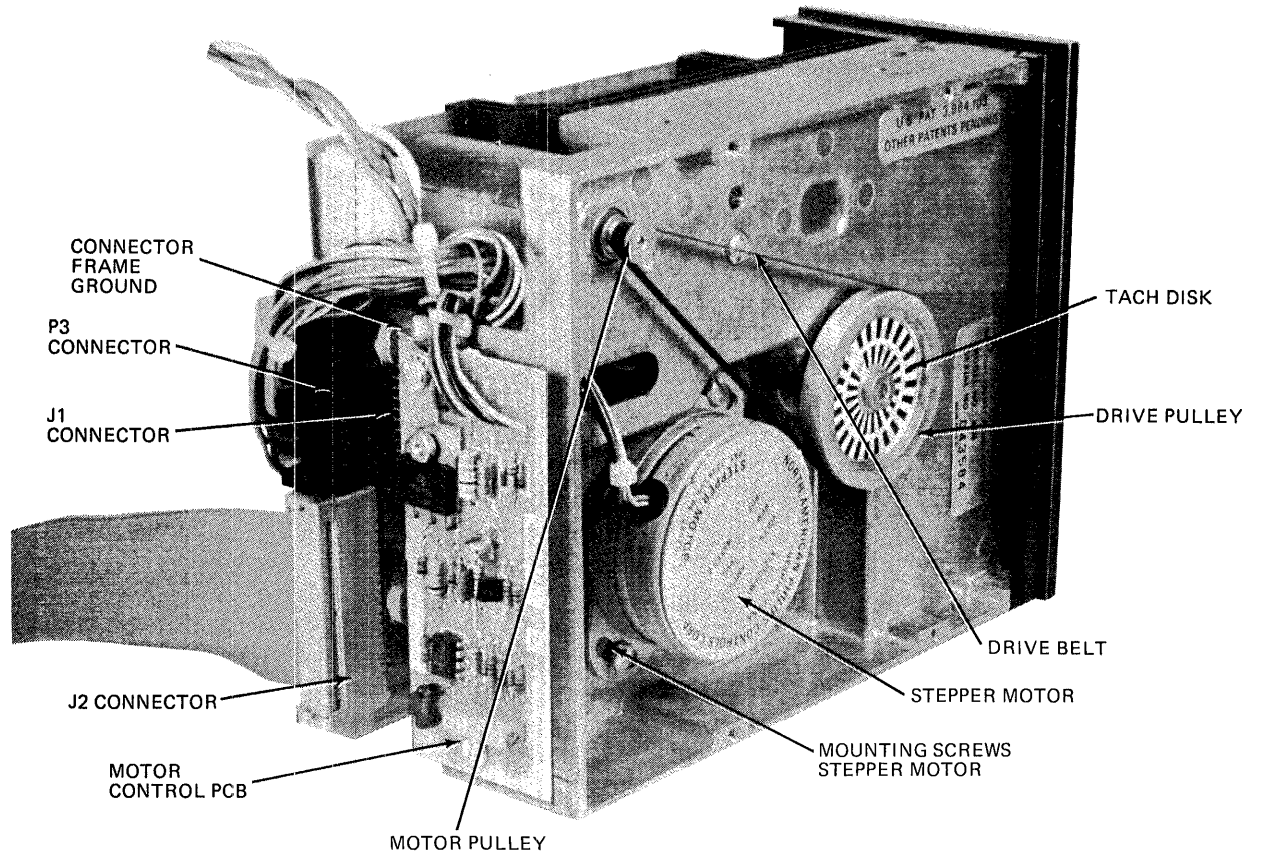



# PCB Component Locations

---

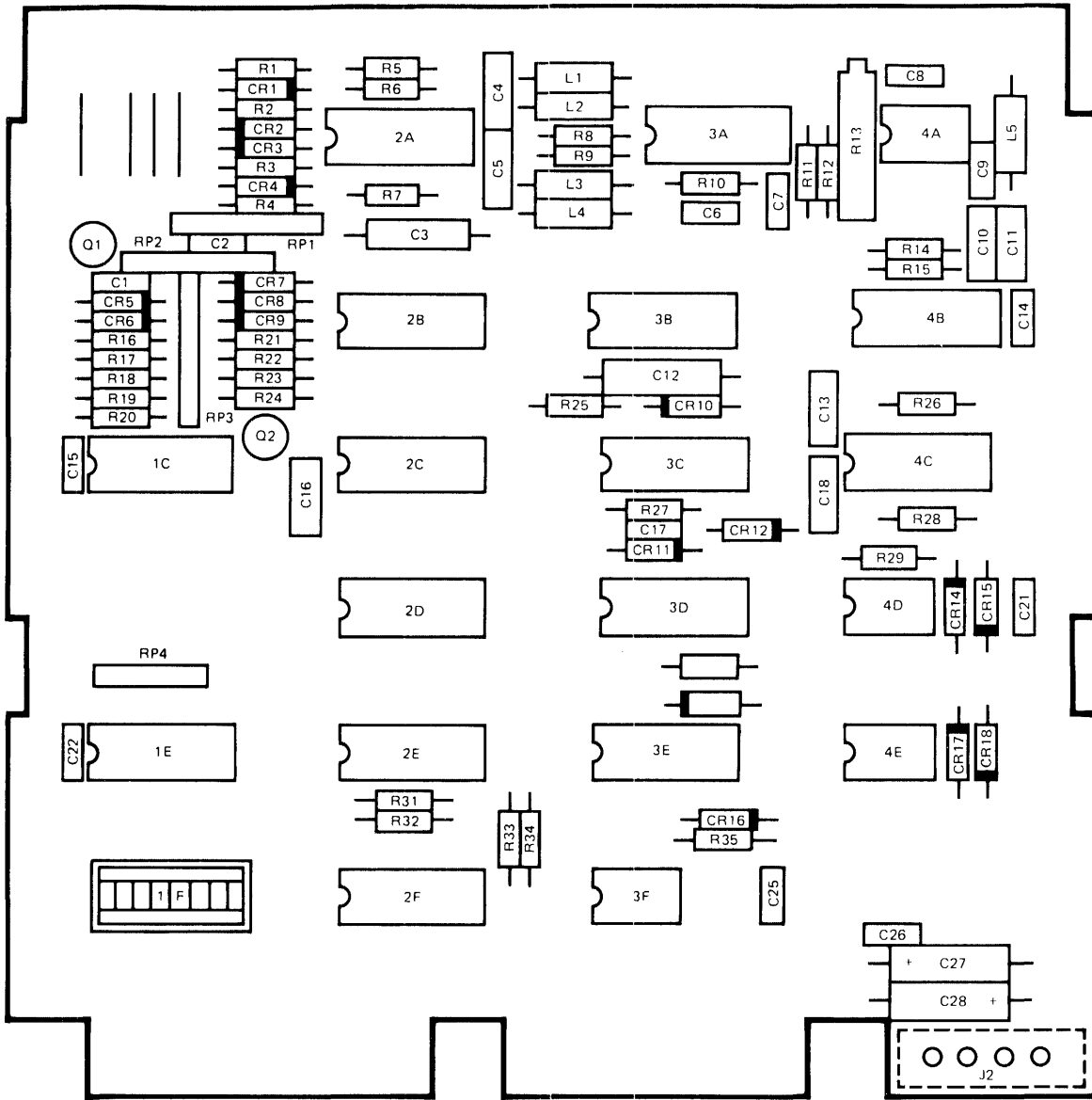

DRIVE PCB  
COMPONENT LOCATIONS

Below E.C. 649

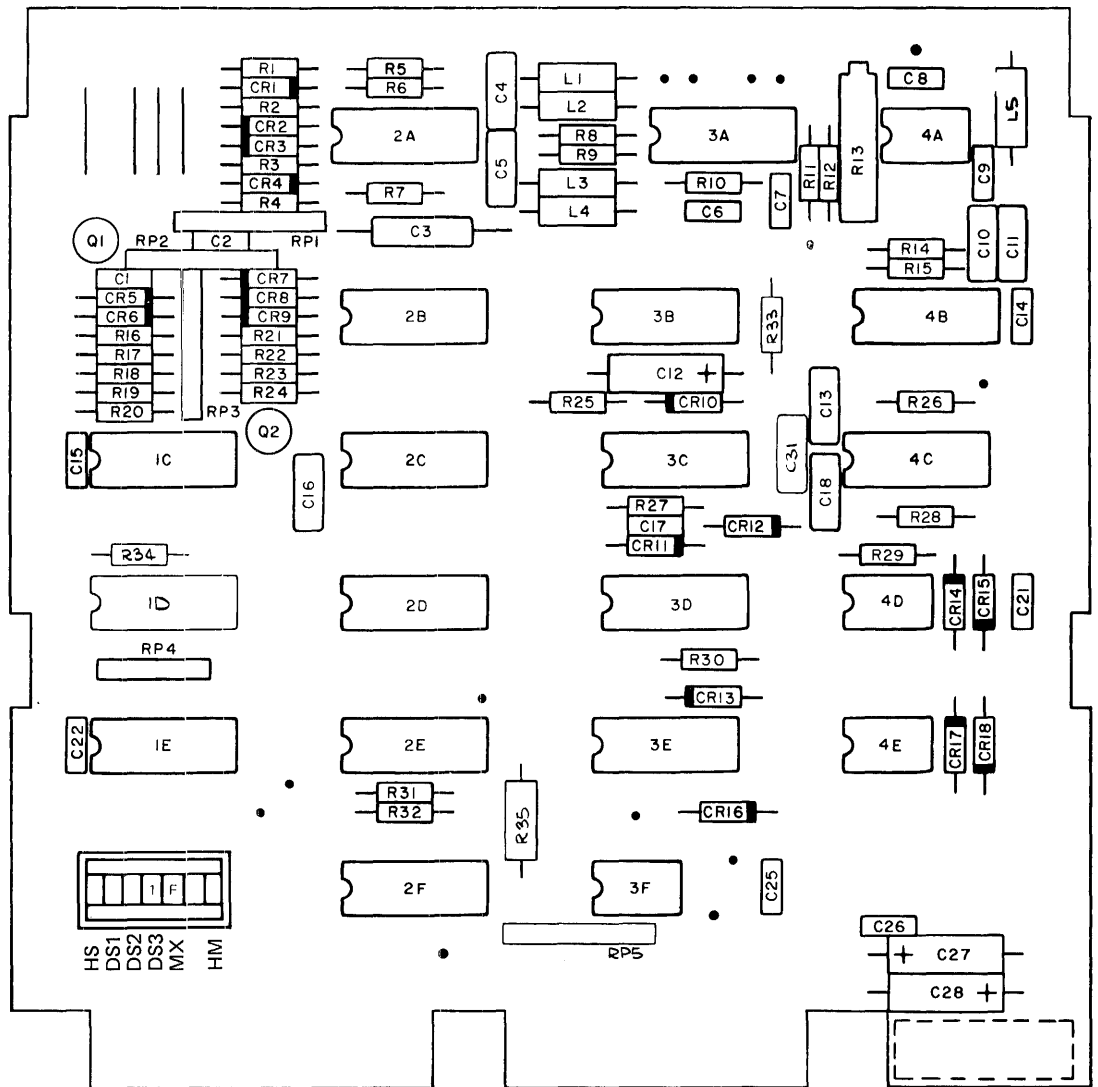

● TEST POINTS

DRIVE PCB  
COMPONENT LOCATIONS

E.C. 649 TO 692

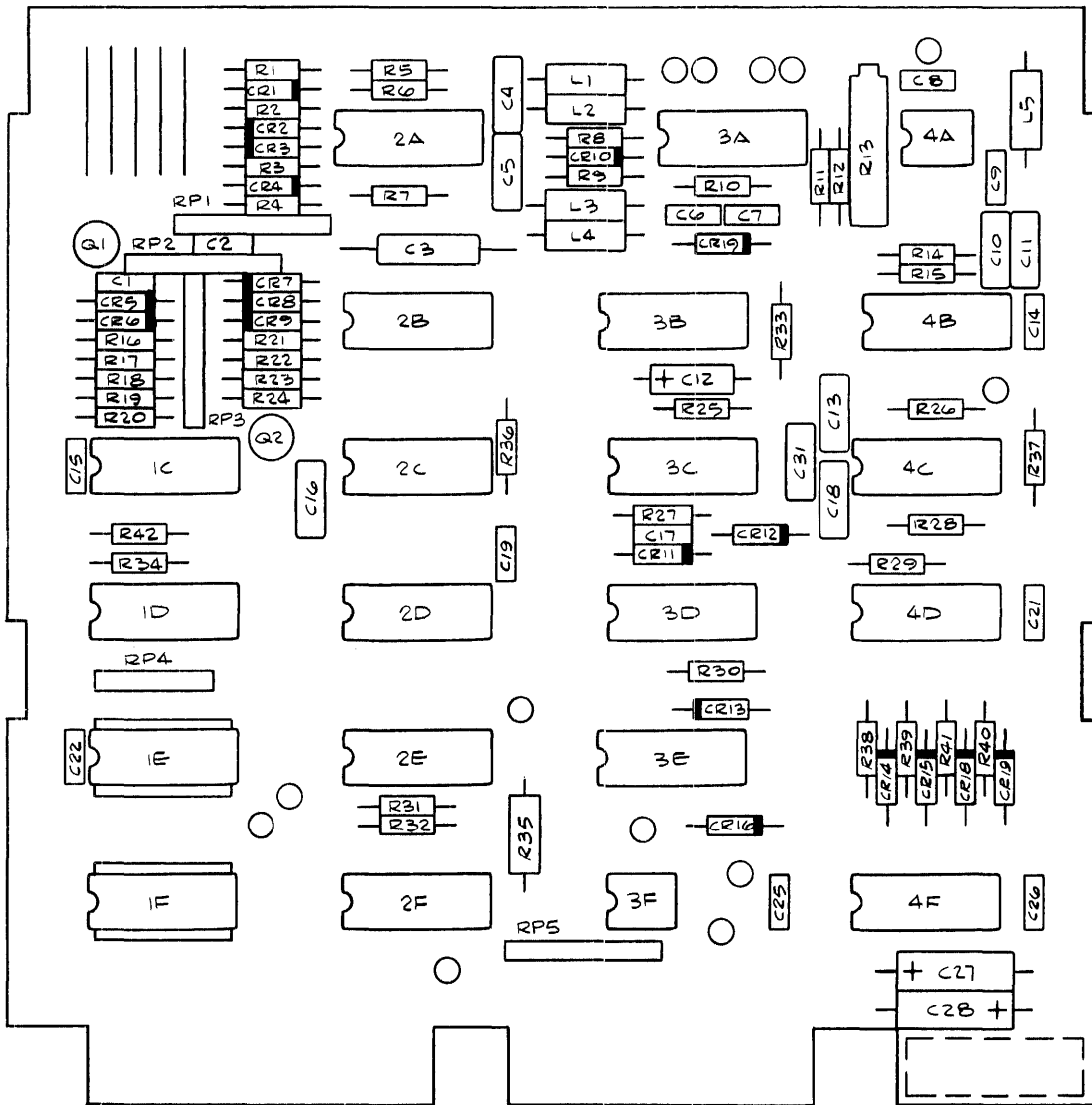

DRIVE PCB  
COMPONENT LOCATIONS

E.C. 692 AND ABOVE



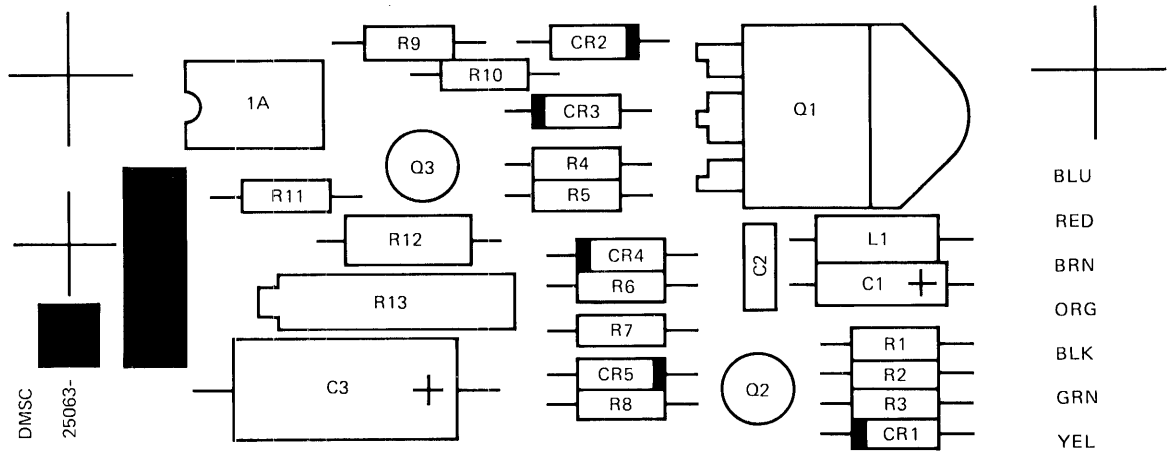

COMPONENT LOCATIONS  
MOTOR CONTROL PCB ASSEMBLY 25063

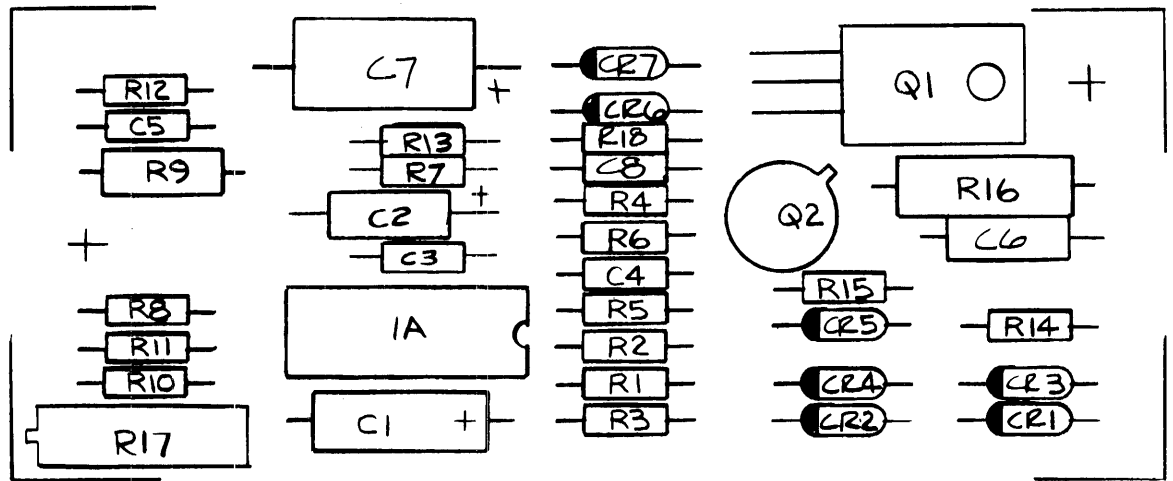

COMPONENT LOCATIONS  
MOTOR CONTROL PCB ASSEMBLY P/N 25129



# Logic Manual

---

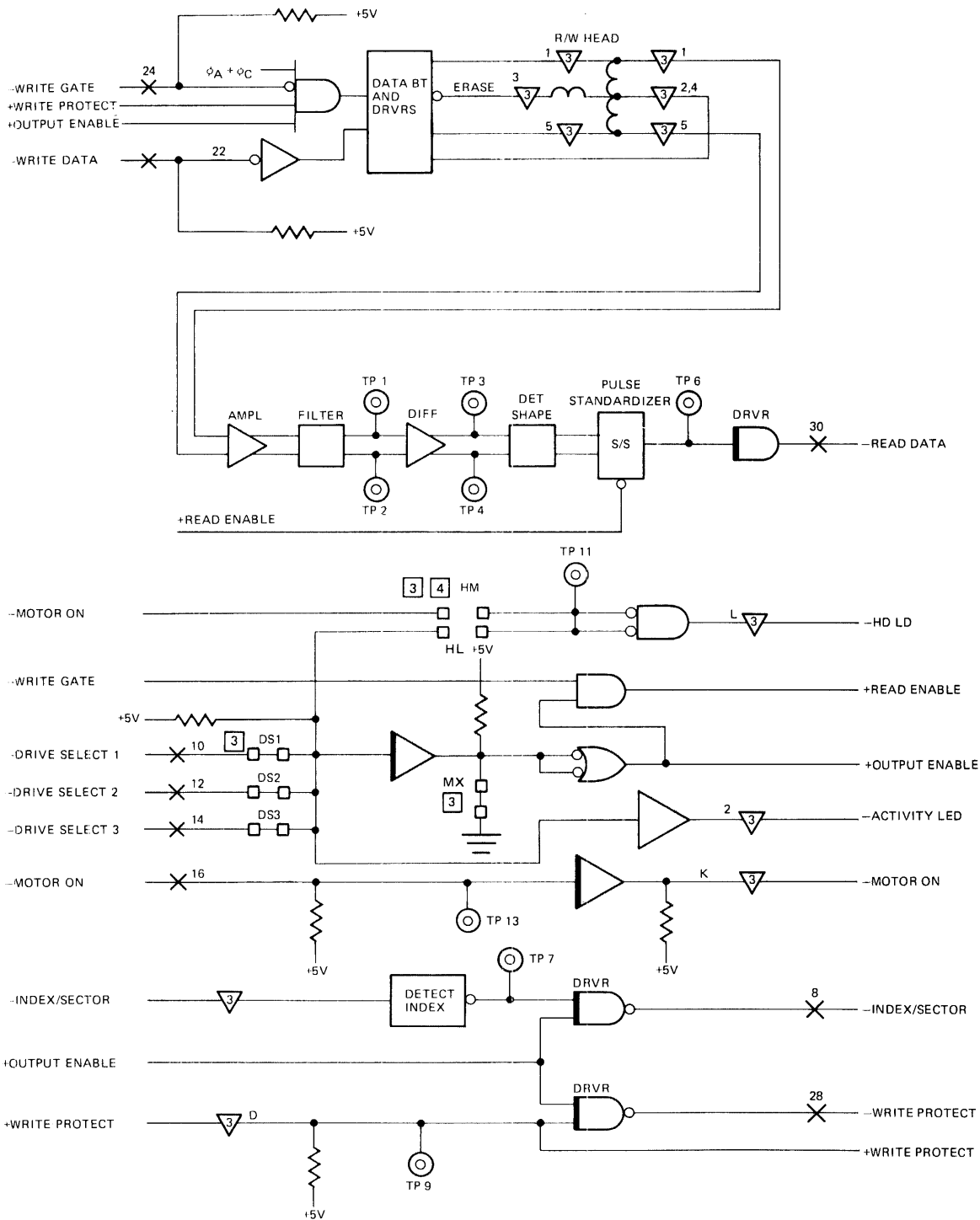

NOTES:

- 1 CONNECTOR SYMBOL REFERENCE -X=J1 ▽=J2 ▽=J3 ▽=J4
- 2 ALL ODD NUMBERED PINS ON J1 CONNECTOR ARE GROUND
- 3 PROGRAM SHUNT
- 4 WITH HM SHORTED HEAD LOADS WITH -MOTOR ON  
WITH HL SHORTED HEAD LOADS WITH -DRIVE SELECT

DRIVE PCB LOGIC DIAGRAM PCBP/N 25060  
 READ/WRITE, INDEX,  
 WRITE PROTECT, DRIVE SELECTION

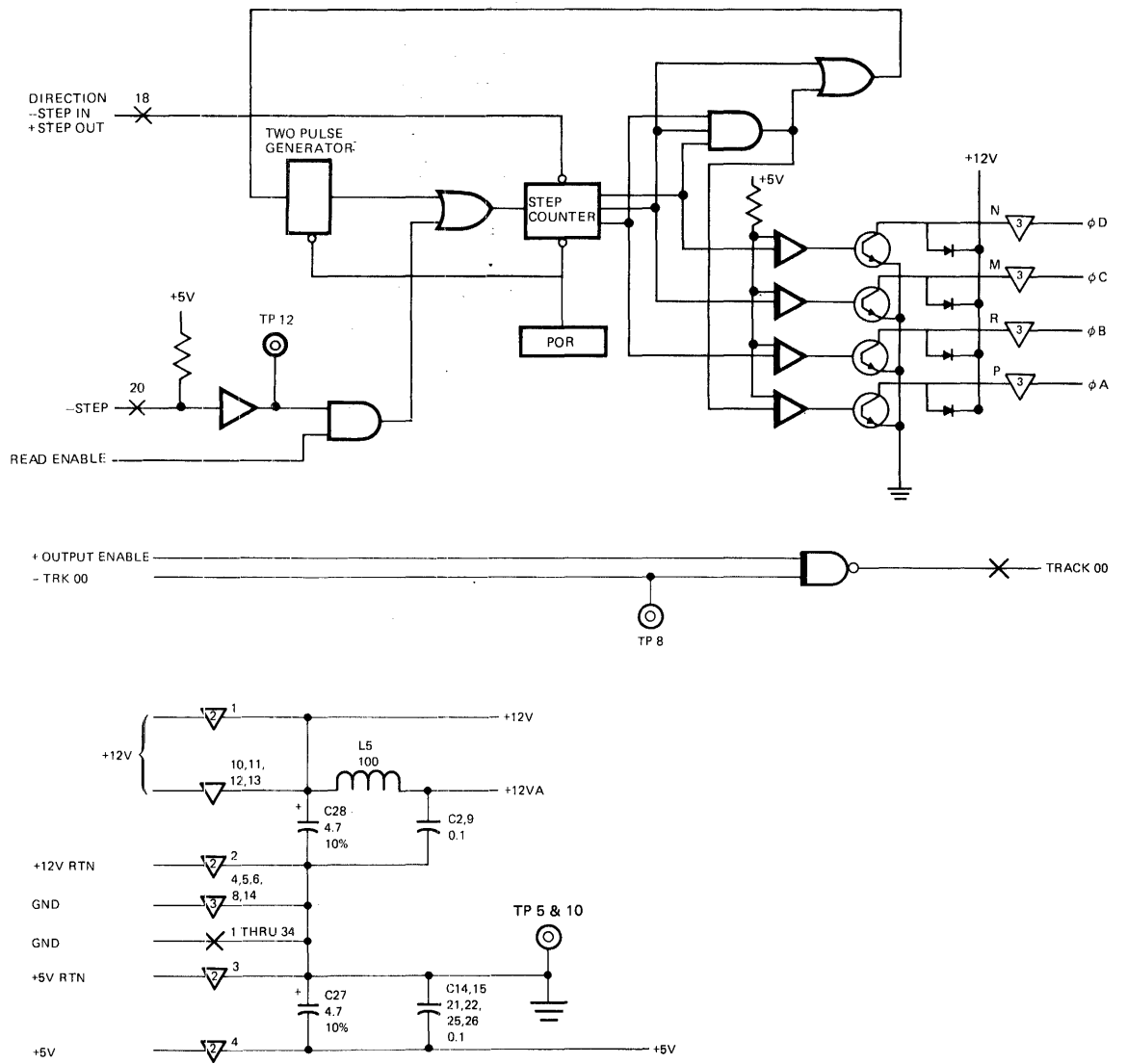

**DRIVE PCB  
STEPPER CONTROLS, TRACK ZERO,  
POWER**

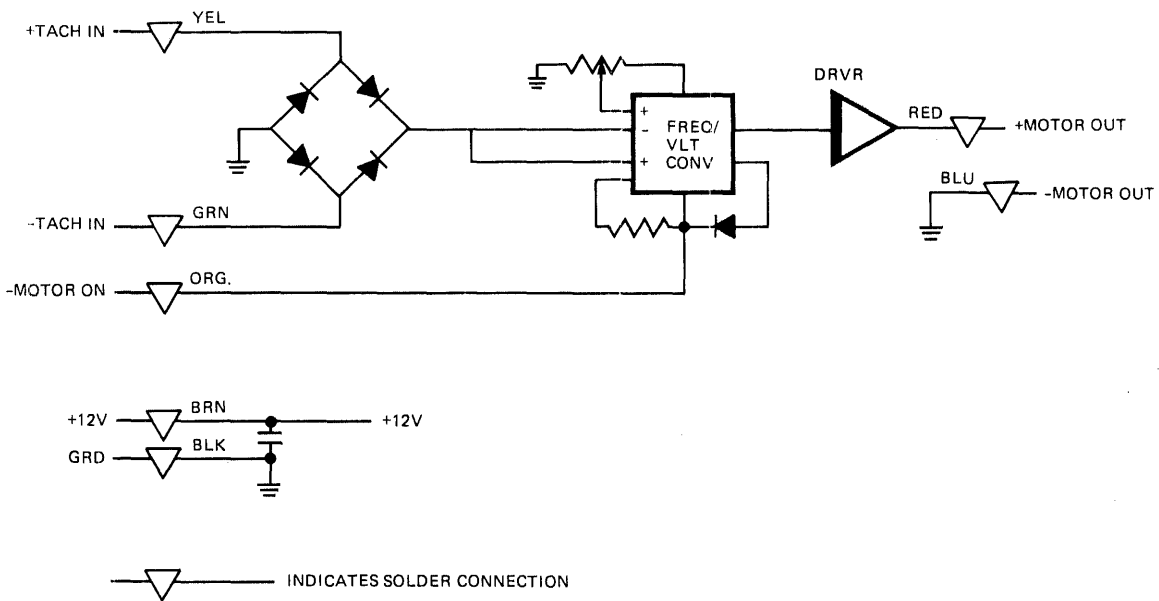

MOTOR SPEED CONTROL PCB LOGIC DIAGRAM  
 AMPLITUDE MODULATION PCB P/N 25129

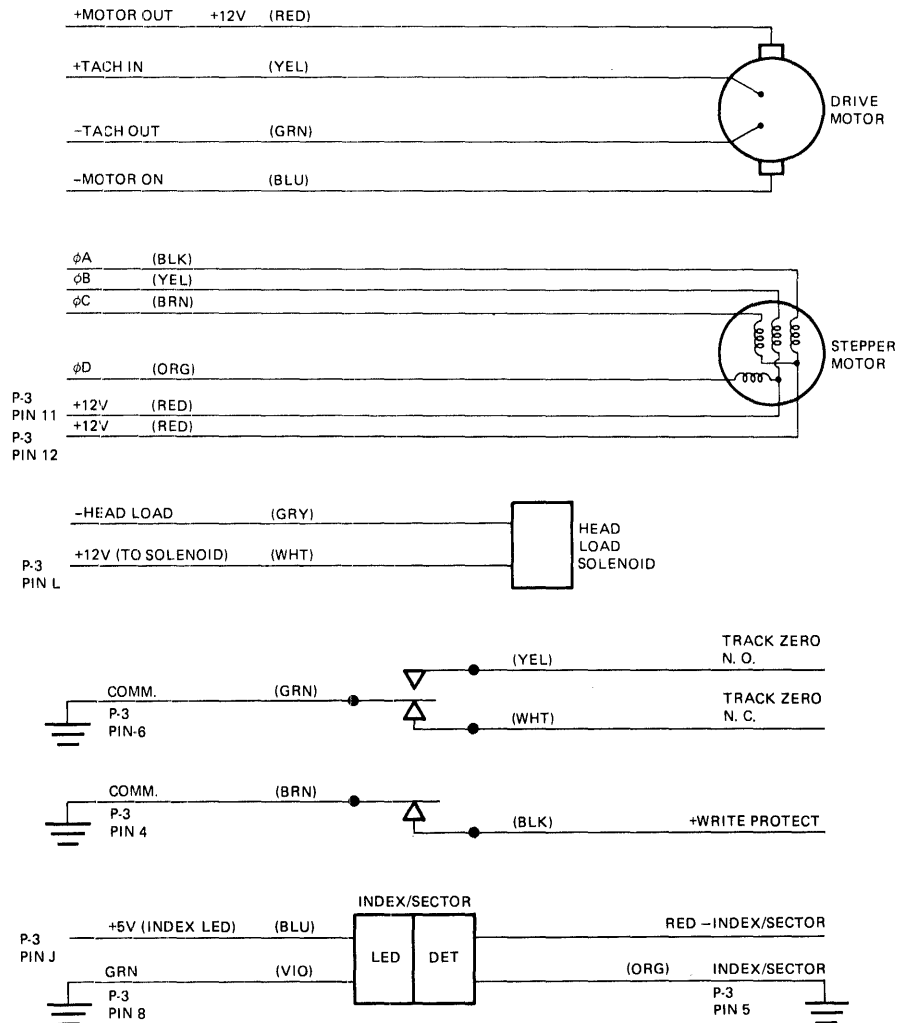

SWITCH AND MOTOR CONNECTIONS





# Schematics

---



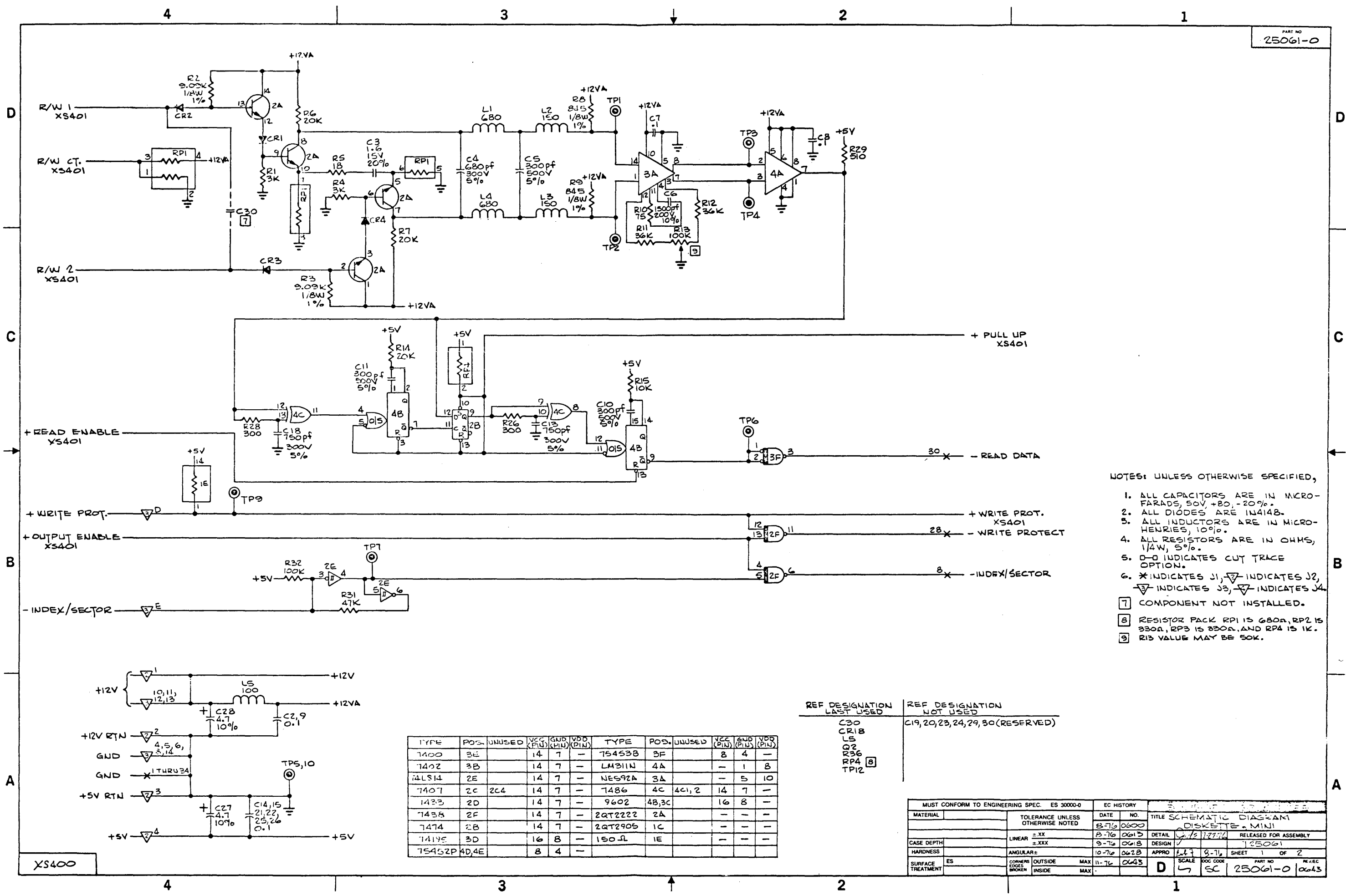

- NOTES: UNLESS OTHERWISE SPECIFIED,
1. ALL CAPACITORS ARE IN MICRO-FARADS, 50V, +80, -20%.
  2. ALL DIODES ARE 1N4148.
  3. ALL INDUCTORS ARE IN MICRO-HENRIES, 10%.
  4. ALL RESISTORS ARE IN OHMS, 1/4W, 5%.
  5. D-D INDICATES CUT TRACE OPTION.
  6. \* INDICATES J1, ▽ INDICATES J2, ▽ INDICATES J3, ▽ INDICATES J4.
  7. COMPONENT NOT INSTALLED.
  8. RESISTOR PACK RPI IS 680Ω, RP2 IS 330Ω, RP3 IS 330Ω, AND RP4 IS 1K.
  9. R13 VALUE MAY BE 50K.

REF DESIGNATION LAST USED	REF DESIGNATION NOT USED
C30 CR18 LS Q2 R36 RP4 TP12	C19, 20, 23, 24, 29, 30 (RESERVED)

MUST CONFORM TO ENGINEERING SPEC. ES 30000-0		EC HISTORY		TITLE SCHEMATIC DIAGRAM DISKETTE - MINI	
MATERIAL	TOLERANCE UNLESS OTHERWISE NOTED	DATE	NO.	DESIGN	RELEASED FOR ASSEMBLY
CASE DEPTH	LINEAR ±.XX ±.XXX	8-76	0600	0613	75061
HARDNESS	ANGULAR ±	9-76	0613	0628	1 OF 2
SURFACE TREATMENT	CORNERS EDGES BROKEN	10-76	0628	0643	SHEET 1 OF 2
	OUTSIDE MAX INSIDE MAX	11-76	0643	D	SCALE DOC CODE PART NO REV/AC
					SC 25061-0 0043

XS400

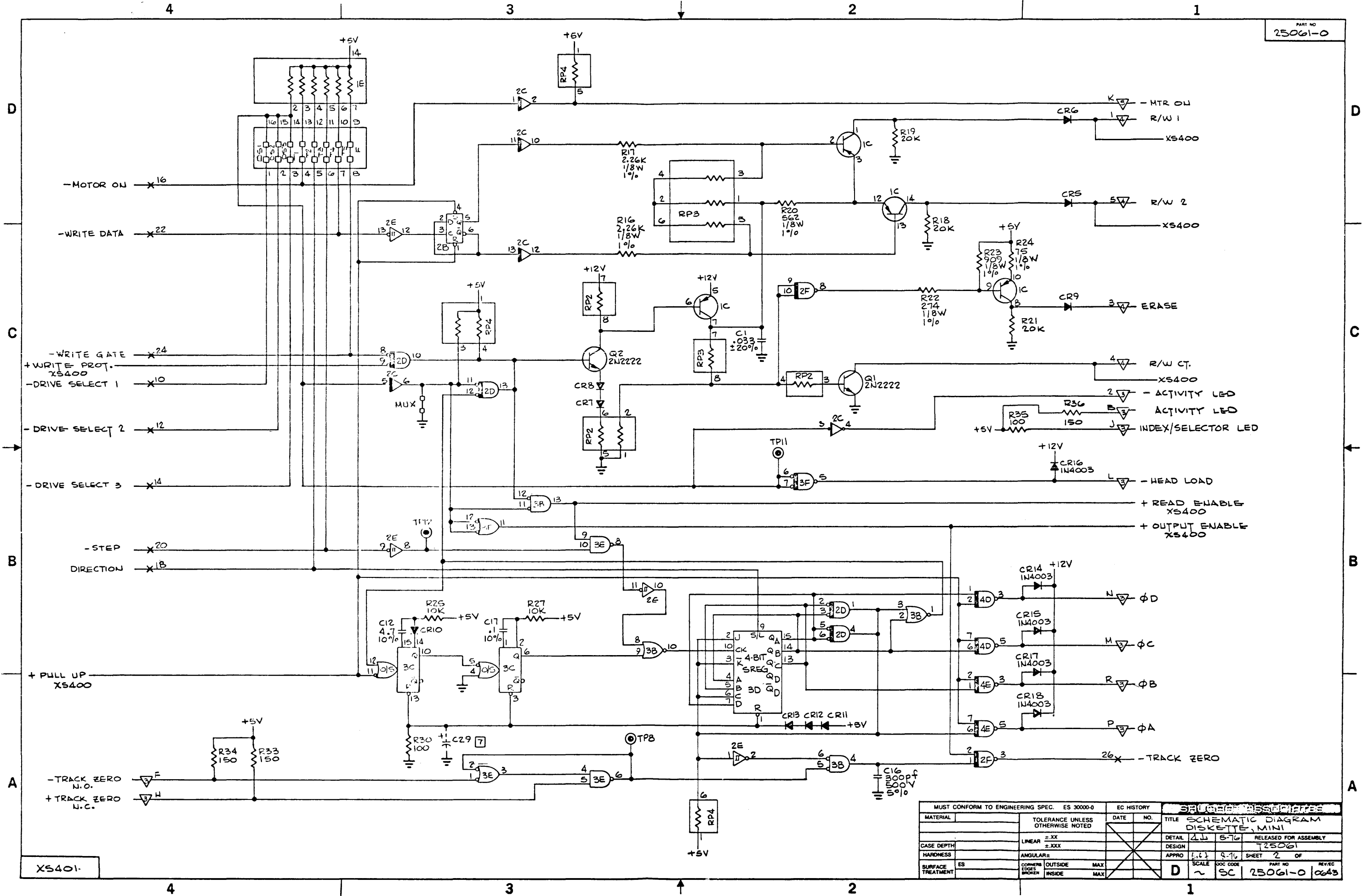

XS401

MUST CONFORM TO ENGINEERING SPEC. ES 30000-0		EC HISTORY		SHURE ASSOCIATES	
MATERIAL	TOLERANCE UNLESS OTHERWISE NOTED	DATE	NO.	TITLE	SCHEMATIC DIAGRAM DISKETTE, MINI
	LINEAR ±.XX			DETAIL	25061-0
CASE DEPTH	±.XXX			DESIGN	RELEASED FOR ASSEMBLY
HARDNESS	ANGULAR ±			APPRO	25061-0
SURFACE TREATMENT	CORNER EDGES BROKEN	OUTSIDE	MAX	SCALE	2 OF 2
		INSIDE	MAX	D	SC 25061-0
					REV EC 0643

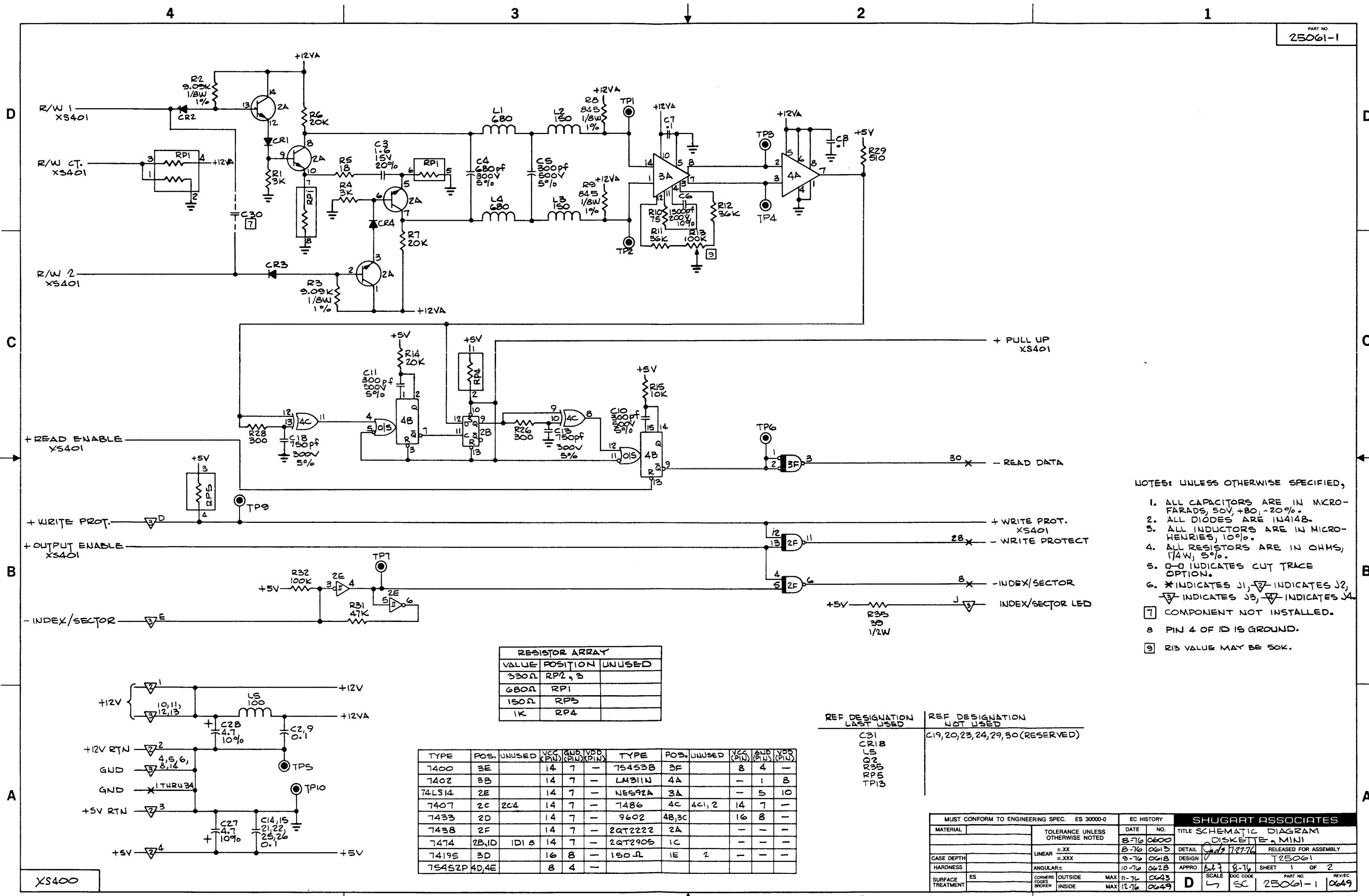

- NOTES: UNLESS OTHERWISE SPECIFIED,
1. ALL CAPACITORS ARE IN MICRO-FARADS, 50V, +80, -20%.
  2. ALL DIODES ARE 1N4148.
  3. ALL INDUCTORS ARE IN MICRO-HENRIES, 10%.
  4. ALL RESISTORS ARE IN OHMS, 1/4W, 5%.
  5. D-D INDICATES CUT TRACE OPTION.
  6. \* INDICATES J1, ▽ INDICATES J2, ▽ INDICATES J3, ▽ INDICATES J4.
  7. COMPONENT NOT INSTALLED.
  8. PIN 4 OF ID IS GROUND.
  9. R13 VALUE MAY BE 50K.

RESISTOR ARRAY

VALUE	POSITION	UNUSED
330Ω	RP2, 3	
680Ω	RP1	
150Ω	RP5	
1K	RP4	

TYPE	POS.	UNUSED	VCC (PIN)	GND (PIN)	VDD (PIN)	TYPE	POS.	UNUSED	VCC (PIN)	GND (PIN)	VDD (PIN)
7400	3E		14	7	-	75453B	3F		8	4	-
7402	3B		14	7	-	LM311N	4A		-	1	8
74LS14	2E		14	7	-	NE592A	3A		-	5	10
7407	2C	2C4	14	7	-	7486	4C	4C1, 2	14	7	-
7433	2D		14	7	-	9602	4B, 3C		16	8	-
7438	2F		14	7	-	2QT2222	2A		-	-	-
7474	2B, 1D	ID1, 8	14	7	-	2QT2905	1C		-	-	-
74195	3D		16	8	-	150Ω	1E	2	-	-	-
75452P	4D, 4E		8	4	-						

REF DESIGNATION LAST USED	REF DESIGNATION NOT USED
C31 CR18 L5 D2 R35 RP5 TP13	C19, 20, 23, 24, 29, 30 (RESERVED)

MUST CONFORM TO ENGINEERING SPEC. ES 30000-0		EC HISTORY		SHUGART ASSOCIATES	
MATERIAL	TOLERANCE UNLESS OTHERWISE NOTED	DATE	NO.	TITLE	SCHEMATIC DIAGRAM
	LINEAR ±.XX ±.XXX	8-76	0600		DISKETTE, MINI
CASE DEPTH		9-76	0613	DESIGN	72776
HARDNESS	ANGULAR ±	10-76	0628	APPRO	1-76
SURFACE TREATMENT	CORNERS BROKEN	11-76	0643	SCALE	8-16
	OUTSIDE MAX 12-76 INSIDE MAX 0649			DOC CODE	SC
				PART NO.	25061-1
				REV/EC	0649

XS400

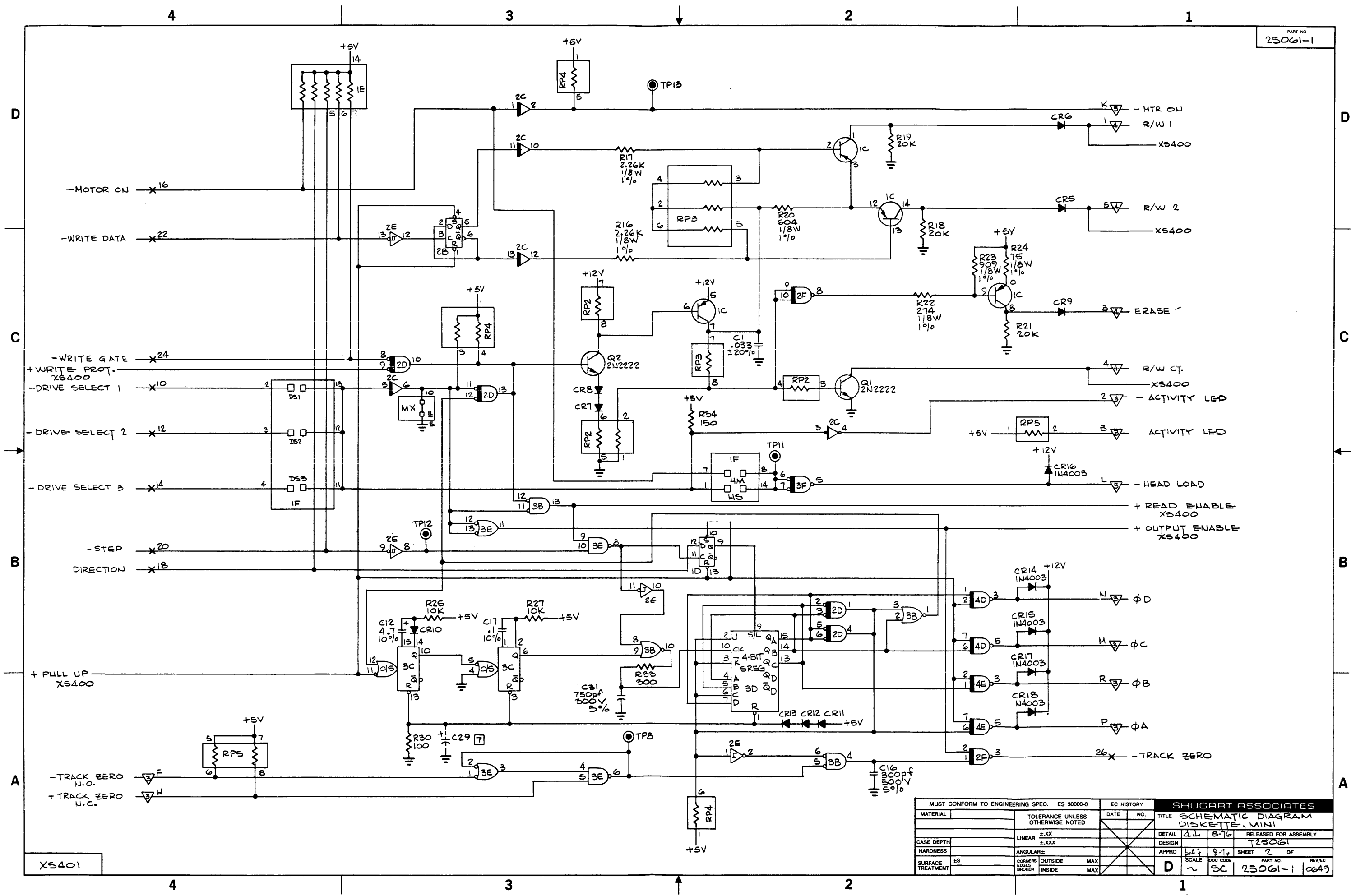

XS401

MUST CONFORM TO ENGINEERING SPEC. ES 30000-0		EC HISTORY		SHUGART ASSOCIATES	
MATERIAL	TOLERANCE UNLESS OTHERWISE NOTED	DATE	NO.	TITLE SCHEMATIC DIAGRAM DISKETTE, MINI	
CASE DEPTH	LINEAR ±.XX ±.XXX			DESIGN	RELEASED FOR ASSEMBLY
HARDNESS	ANGULAR:—			APPRO	725061
SURFACE TREATMENT	CORNERS BROKEN OUTSIDE INSIDE MAX MAX			SCALE	SHEET 2 OF
				DOC CODE	PART NO. REV/EC
				25061-1	0649

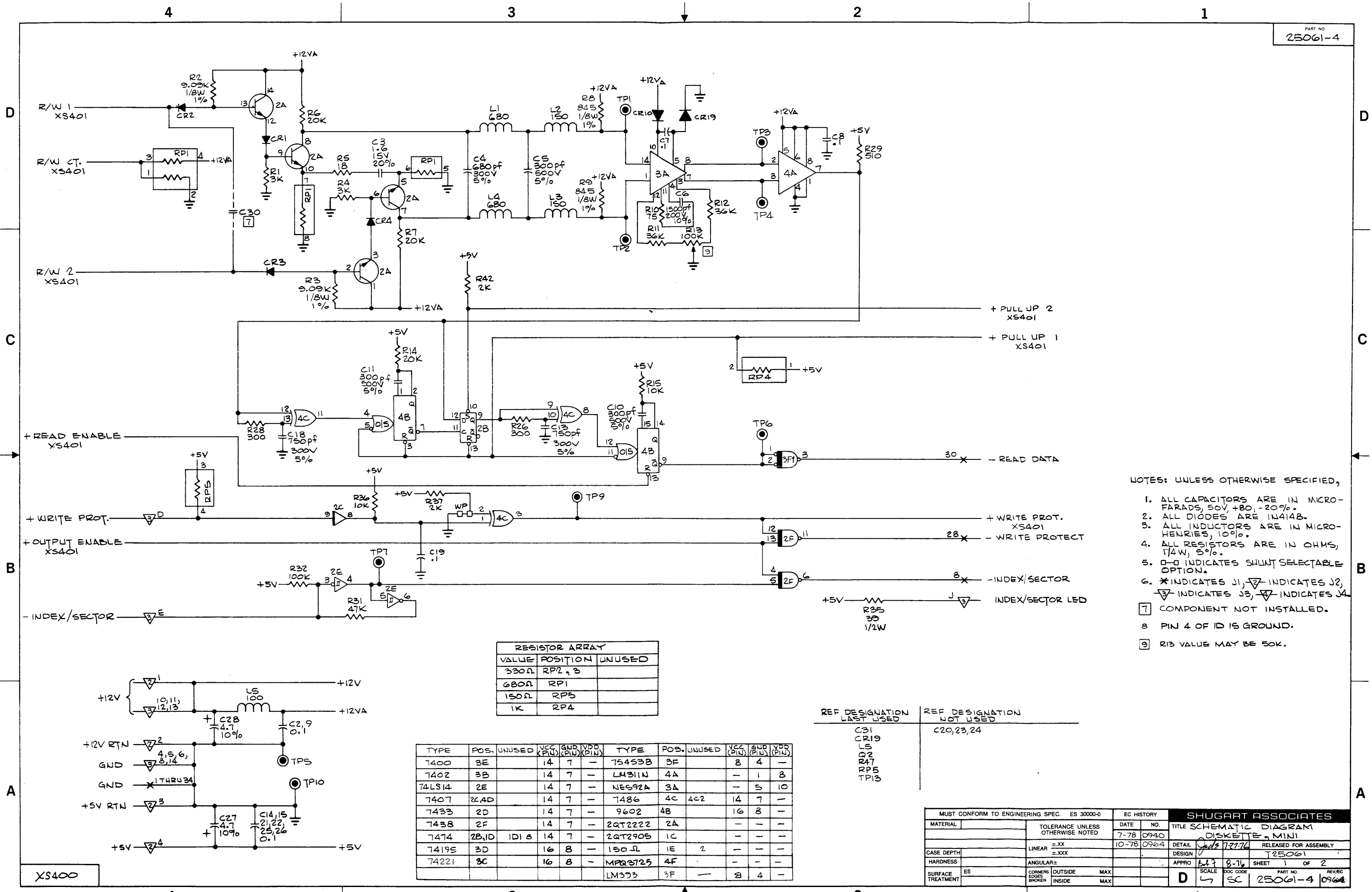

- NOTES: UNLESS OTHERWISE SPECIFIED,
1. ALL CAPACITORS ARE IN MICRO-FARADS, 50V, +80, -20%.
  2. ALL DIODES ARE 1N4148.
  3. ALL INDUCTORS ARE IN MICRO-HENRIES, 10%.
  4. ALL RESISTORS ARE IN OHMS, 1/4W, 5%.
  5. 0-0 INDICATES SHUNT SELECTABLE OPTION.
  6. \* INDICATES J1, ▽ INDICATES J2, ▽ INDICATES J3, ▽ INDICATES J4.
  7. COMPONENT NOT INSTALLED.
  8. PIN 4 OF ID IS GROUND.
  9. R13 VALUE MAY BE 50K.

RESISTOR ARRAY

VALUE	POSITION	UNUSED
330Ω	RP2, 3	
680Ω	RP1	
150Ω	RP5	
1K	RP4	

TYPE	POS.	UNUSED	VCC (PIN)	GND (PIN)	VDD (PIN)	TYPE	POS.	UNUSED	VCC (PIN)	GND (PIN)	VDD (PIN)
7400	3E		14	7	-	75453B	3F		8	4	-
7402	3B		14	7	-	LM311N	4A		-	1	8
74LS14	2E		14	7	-	NE592A	3A		-	5	10
7407	2C,4D		14	7	-	7486	4C	4c2	14	7	-
7433	2D		14	7	-	9602	4B		16	8	-
7438	2F		14	7	-	2QT2222	2A		-	-	-
7474	2B,1D	ID1 8	14	7	-	2QT2905	1C		-	-	-
7419E	3D		16	8	-	150Ω	1E	2	-	-	-
74221	3C		16	8	-	MPQ3725	4F		-	-	-
						LM373	3F		8	4	-

REF DESIGNATION LAST USED	REF DESIGNATION NOT USED
C31 CR19 LS D2 R47 RP5 TP13	C20,23,24

MUST CONFORM TO ENGINEERING SPEC. ES 30000-0		EC HISTORY		SHUGART ASSOCIATES	
MATERIAL	TOLERANCE UNLESS OTHERWISE NOTED	DATE	NO.	TITLE SCHEMATIC DIAGRAM	
		7-78	0940	DISKETTE, MINI	
CASE DEPTH	LINEAR ±.XX	DESIGN	10-78	0964	RELEASED FOR ASSEMBLY
HARDNESS	ANGULAR ±	APPRO	6/7	8-76	J25061
SURFACE TREATMENT	CORNERS BROKEN	SCALE	5	SHEET	1 OF 2
	OUTSIDE MAX	PART NO.	25061-4	REV/EC	0964
	INSIDE MAX				

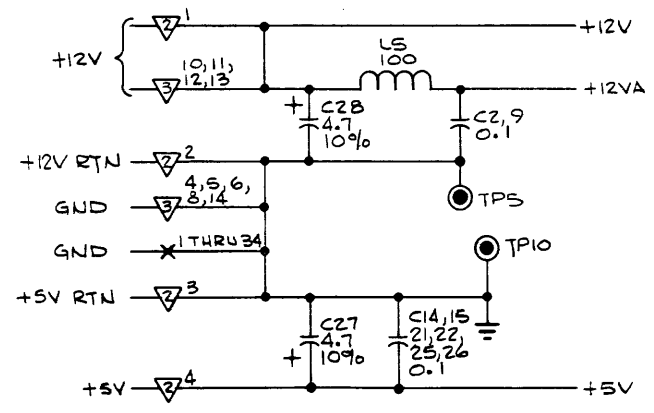

XS400

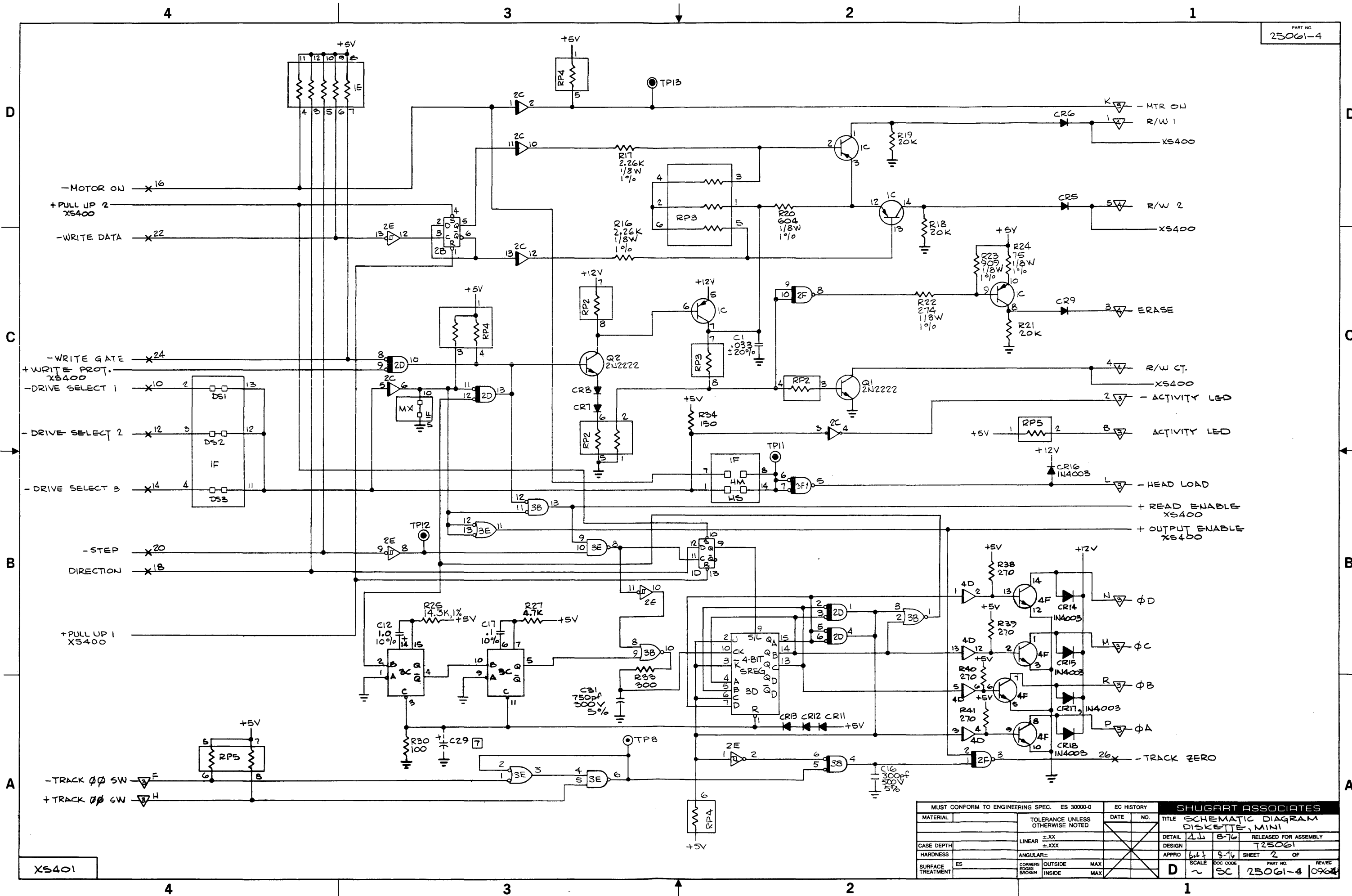

XS401

MUST CONFORM TO ENGINEERING SPEC. ES 30000-0		EC HISTORY		SHUGART ASSOCIATES			
MATERIAL	TOLERANCE UNLESS OTHERWISE NOTED	DATE	NO.	TITLE SCHEMATIC DIAGRAM DISKETTE, MINI			
				DETAIL	41	676	RELEASED FOR ASSEMBLY
CASE DEPTH	LINEAR ±.XX ±.XXX			DESIGN			T25061
HARDNESS	ANGULAR ±			APPRO	6/1	8-16	SHEET 2 OF
SURFACE TREATMENT	ES			SCALE			DOC CODE
	CORNERS EDGES BROKEN	OUTSIDE INSIDE	MAX MAX	D	~	SC	PART NO. 25061-4 REV/EC 09/64



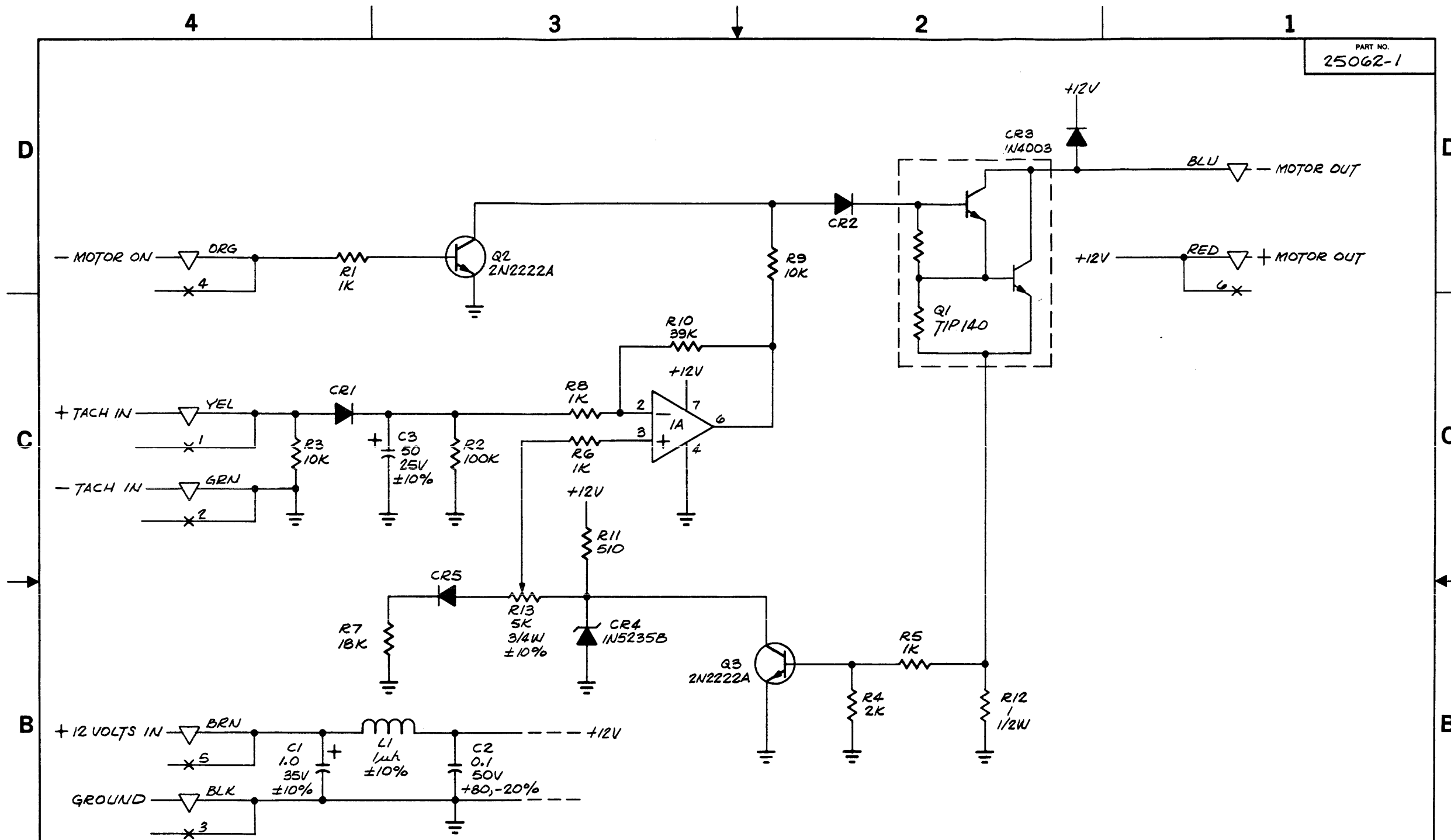

NOTES; UNLESS OTHERWISE SPECIFIED,  
 1. ALL CAPACITORS ARE IN MICROFARADS.  
 2. ALL DIODES ARE 1N4148.  
 3. ALL RESISTORS ARE IN OHMS, 1/4W, ±5%.  
 4. ▽ INDICATES SOLDERED WIRE CONNECTION.

REF DESIGNATION LAST USED	REF DESIGNATION NOT USED
C3	
CR5	
L1	
Q3	
R13	

MUST CONFORM TO ENGINEERING SPEC. ES 30000-0		EC HISTORY		SHUGART ASSOCIATES		
MATERIAL	TOLERANCE UNLESS OTHERWISE NOTED	DATE	NO.	TITLE SCHEMATIC DIAGRAM		
	LINEAR ±.XX	8-76	0600	DRV MTR & SPEED CTRL (AM)		
CASE DEPTH	ANGULAR ±	8-76	0613	DESIGN	4-W.	5-76
HARDNESS		9-76	0622	DETAIL		RELEASED FOR ASSEMBLY
SURFACE TREATMENT	CORNERS BROKEN			APPRO	bit 7	8-76
	OUTSIDE MAX			SCALE	~	SHEET 1 OF 1
	INSIDE MAX			DOC CODE	SC	PART NO. 25062-1
				REVISED		0622



# Illustrated Parts Catalog

---

## Section 3

# Table of Contents

---

Description . . . . .	1
Drive Assembly . . . . .	3
Numeric Index . . . . .	4

## **DESCRIPTION**

### **General**

The Illustrated Parts Catalog is arranged so that the figures precede the parts listings and will be on the opposite page.

The drive assembly is contained on a single page. Sub assemblies will be separated by a solid line and are broken down on this page.

### **Indented Level**

The parts list is indented to show the levels of assembly within a figure. The major assembly will always be level 1, all parts or assemblies that attach to that assembly will be level 2 and assemblies within level 2 will have their attaching parts level 3 and so on.

### **Parts Replacement**

Some parts and assemblies are not field replaceable. These will be noted by an asterisk\* and a footnote. These part numbers are included so they can be ordered for factory and/or repair centers.

### **Quantity Per Assembly**

The quantity listed is the quantity used on the assembly.

### **Numerical Index**

The numerical index lists all parts in part number sequence and is cross referenced to the figure and reference number.

### **Note:**

Figure 1 is the Illustrated Parts Breakdown for the original SA400, Figure 2 represents the current configuration (EC692).

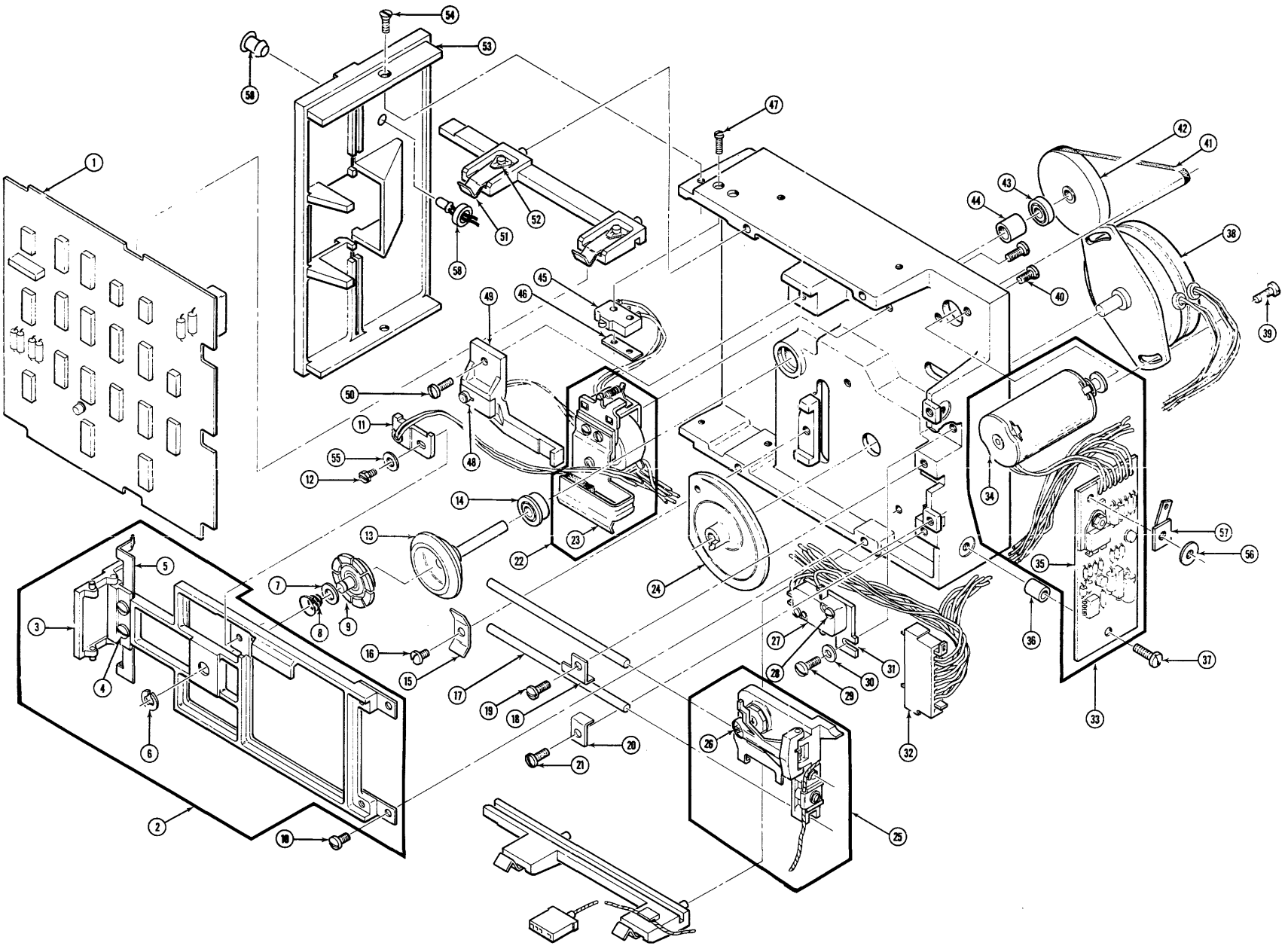

Figure 1

FIGURE & REF. NUMBER	PART NUMBER	DESCRIPTION				QTY PER ASM
		1	2	3	4	
1						
				DRIVE ASSEMBLY		
- 1	25060			. PCB, DRIVE		1
- 2	54070			. HUB FRAME ASSEMBLY		1
- 3	54073			. . DOOR HINGE		1
- 4	10186			. . SCREW 6-32 X .188 BH		2
- 5	54057			. . STOPDISK		1
- 6	11305			. . E-RING		1
- 7	54131			. . COLLAR HUB		1
- 8	54132			. . SPRING, CLAMP		1
- 9	54066			. . HUB, COLLETT		1
-10	10186			. SCREW 6-32X.188 BH		2
-11	54136			. DETECTOR INDEX		1
-12	10187			. SCREW 6-32X.188 BH		1
-13	* 54032			. SPINDLE		1
-14	* 10805			. BEARING, FLANGED		1
-15	54078			. KEEPER, GUIDE ROD		1
-16	10186			. SCREW 6-32X.188 BH		1
-17	54006			. GUIDE ROD		2
-18	54099			. STOP, CARRIAGE		1
-19	10186			. SCREW 6-32X.188 BH		1
-20	54078			. KEEPER GUIDE ROD		1
-21	10186			. SCREW 6-32X.188 BH		1
-22	54064			. SOLENOID ASSMY. HEAD LOAD		1
-23	54135			. . BAIL, LOAD		1
-24	54003			. CAM, ACTUATOR		1
-25	54055			. HEAD & CARRIAGE ASSMY.		1
-26	54145			. . LOAD BUTTON		1
-27	17211			. TK 00 SWITCH		1
-28	10176			. SCREW 4-40X.50 BH		2
-29	10187			. SCREW 6-32X.250 BH		1
-30	10013			. WASHER		1
-31	54038			. MOUNT TK 00 SWITCH		1
-32	15655			. CONNECTOR P-3		1
-33	54067			. MOTOR & CONTROL ASSEMBLY		1
-34	54047			. . MOTOR DRIVE		1
-35	25063			. . PCB MOTOR CONTROL		1
-36	54069			. STANDOFF, MOTOR PCB		2
-37	10191			. SCREW 6-32X.50 BH		2
-38	* 54068			. MOTOR, STEPPER		1
-39	10187			. SCREW 6-32X.250 BH		2
-40	10177			. SCREW 4-40X.625 BH		2
-41	54048			. BELT, DRIVE		1
-42	* 54138			. PULLEY, SPINDLE		1
-43	* 10804			. BEARING		1
-44	* 54097			. SPACER, LONG		1
-45	17212			. SWITCH WRITE PROTECT		1
-46	54062			. NUT PLATE		1
-47	10166			. SCREW 2-56X.50 BH		1
-48	54137			. LED, INDEX		1
-49	54125			. PLATEN		1
-50	10189			. SCREW 6-32X.250 BH		1
-51	54036			. CLAMP, PCB		4
-52	11311			. RETAINER, CLAMP		4
-53	54077			. FACEPLATE		1
-54	11900			. 6-32X.250 F.H.		2
-55	10013			. WASHER		1
-56	12501			. WASHER		1
-57	15663			. FASTON		1
-58	11312			. ACTIVITY LIGHT HOLDER		1
-59	15915			. LED ACTIVITY LIGHT		1
-60	* 54089			. GUIDE DISKETTE R.H.		1
-61	* 54090			. GUIDE DISKETTE L. H.		1
				* NOT FIELD REPLACEABLE		

PART NUMBER	REF.
10013	55
10166	47
10176	28
10177	40
10186	4
	10
	12
	16
	19
	21
10187	12
	29
	39
10189	50
10191	37
10804	43
10805	14
11305	6
11311	52
11312	58
11900	54
12501	56
15655	32
15663	57
17211	27
17212	45
25060	1
25063	35
54003	24
54006	17
54032	13
54036	51
54038	31
54047	34
54048	41
54055	25
54057	5
54062	46
54064	22
54065	36
54066	9
54067	33
54068	38
54070	2
54073	3
54077	53
54078	15
	20

PART NUMBER	REF.
54089	60
54090	61
54097	44
54099	18
54125	49
54131	7
54132	8
54135	23
54136	11
54137	48
54138	42
54145	26



Figure 2

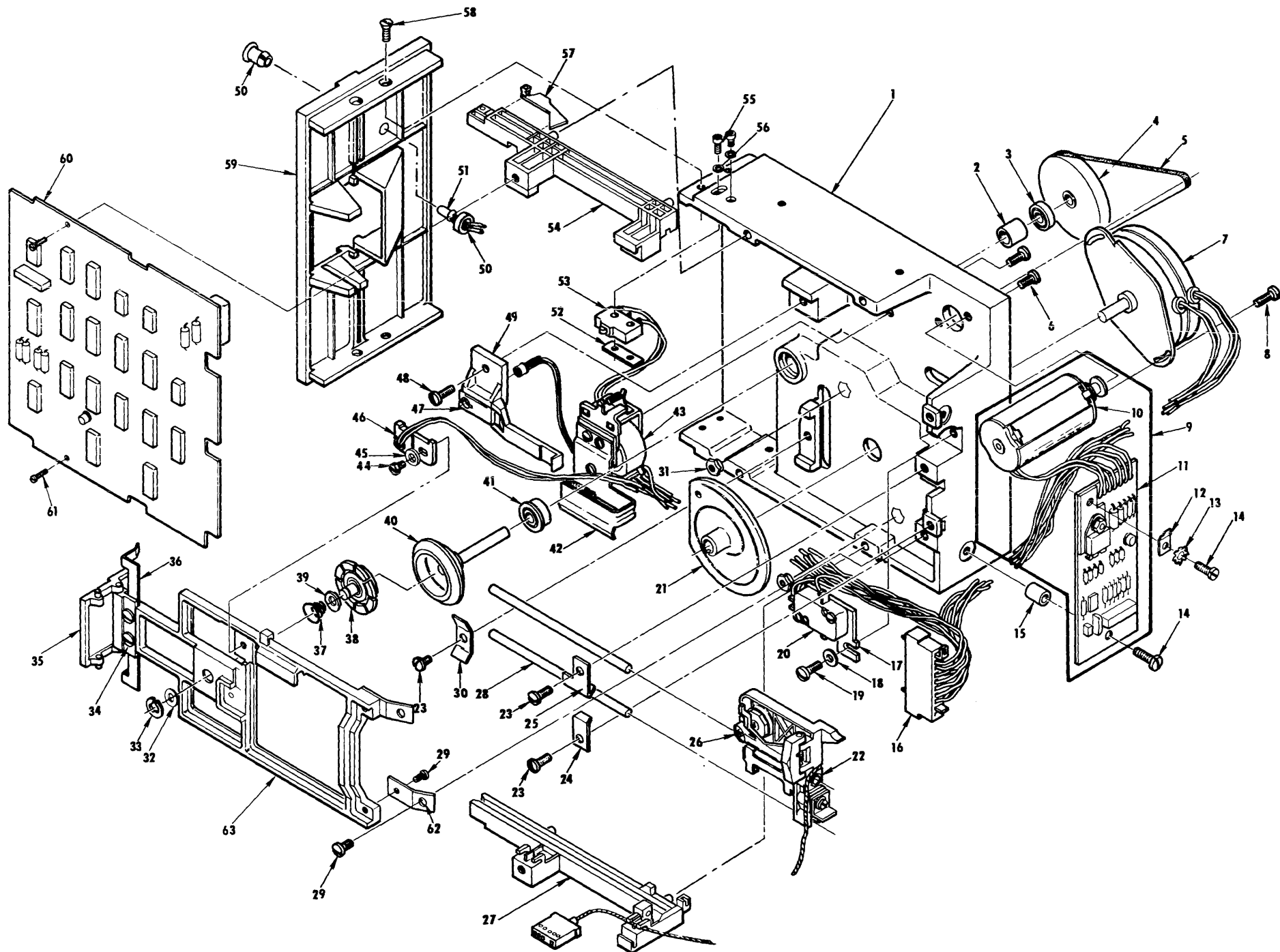

FIGURE & REF. NUMBER	PART NUMBER	DESCRIPTION				QTY PER ASM	
		1	2	3	4		
2						DRIVE ASSEMBLY	
- 1	54479	.				BASE CASTING	1
- 2	* 54097	.				SPACER, LONG	1
- 3	* 10804	.				BEARING	1
- 4	* 54138	.				PULLEY, SPINDLE	1
- 5	54161	.				BELT, DRIVE	1
- 6	10187	.				SCREW 6-32 x .250 BH	2
- 7	* 54068	.				MOTOR, STEPPER	1
- 8	10186	.				SCREW 6-32 x .188 BH	2
- 9	54508	.				MOTOR AND CONTROL ASSEMBLY	1
-10	54047	.				MOTOR, DRIVE (WITH SHIELD, P/N 54507)	1
-11	25129	.				PCB MOTOR CONTROL	1
-12	15663	.				FASTON	1
-13	12501	.				WASHER	1
-14	10191	.				SCREW 6-32 x .500 BH	2
-15	54065	.				STANDOFF, MOTOR PCB	2
-16	54056	.				CONNECTOR, P3	1
-17	54038	.				MOUNT TRACK 00 SWITCH	1
-18	10013	.				WASHER, FLAT #6	1
-19	10187	.				SCREW 6-32 x .250 BH	1
-20	17211	.				SWITCH, TRACK 00	1
-21	54003	.				CAM, ACTUATOR	1
-22	54055	.				HEAD AND CARRIAGE ASSEMBLY	1
-23	10185	.				SCREW, 6-32 x .200-.125 BH	1
-24	54474	.				CLAMP, CARRIAGE STOP	1
-25	54473	.				CLAMP, GUIDE ROD	1
-26	54145	.				LOAD BUTTON	1
-27	* 54475	.				GUIDE DISKETTE RH	1
-28	54006	.				GUIDE ROD	2
-29	10186	.				SCREW 6-32 x .188 BH	4
-30	54078	.				KEEPER, GUIDE ROD	1
-31	11714	.				NUT, CAPTIVE	2
-33	11305	.				E-RING	1
-34	10186	.				SCREW 6-32 x .188 BH	2
-35	54073	.				DOOR, HINGE	1
-36	54057	.				STOP DISK	1
-37	54132	.				SPRING CLAMP	1
-38	54066	.				HUB, COLLET	1
-39	54131	.				COLLAR, HUB	1
-40	* 54032	.				SPINDLE	1
-41	* 10805	.				BEARING, FLANGED	1
-42	54135	.				BAIL, LOAD	1
-43	54064	.				HEAD LOAD SOLENOID ASSEMBLY	1
-44	10187	.				SCREW 6-32 x .250 BH	1
-45	10013	.				WASHER, FLAT #6	1
-46	54136	.				DETECTOR, INDEX	1
-47	54137	.				INDEX LED	1
-48	10189	.				SCREW 6-32 x .375 BH	1
-49	54125	.				PLATEN	1
-50	11312	.				ACTIVITY LIGHT HOLDER	1
-51	15915	.				LED ACTIVITY LIGHT	1
-52	54062	.				NUT PLATE	1
-53	17212	.				SWITCH WRITE PROTECT	1
-54	* 54040	.				GUIDE DISKETTE LH	1
-55	12039	.				SCREW 2-56 x .50 SOC HD	2
-56	10011	.				WASHER 2-56	2
-57	54030	.				ACTUATOR SWITCH	1
-58	11900	.				SCREW 6-32 x .250 FH	4
-59	54077	.				FACEPLATE	1
-60	25060	.				PCB, DRIVE	1
-61	10172	.				SCREW 4-40 x .180	2
-62	54024	.				SPRING HINGE	2
-63	54070	.				HUB	1

PART NUMBER	REF.
10011	56
10013	18
	45
10172	61
10185	23
10186	8
	29
	34
10187	6
	19
	44
10189	48
10191	14
10804	3
10805	41
11305	33
11312	50
11714	31
11900	58
12039	55
12501	13
12512	32
15663	12
15915	51
17211	20
17212	53
25060	60
25129	11
54003	21
54006	28
54024	62
54030	56
54032	40
54038	17
54040	54
54047	10
54055	22
54056	16
50057	36

PART NUMBER	REF.
54062	52
54064	43
54065	15
54066	38
54068	7
54070	63
54073	35
54077	59
54078	30
54097	2
54125	49
54131	39
54132	37
54135	42
54136	46
54137	47
54138	4
54145	26
54161	5
54473	25
54474	24
54475	27
54479	1
54507	10
54508	9



435 Oakmead Parkway Sunnyvale, California 94086  
Telephone: (408) 733-0100 TWX: 910-339-9355 SHUGART SUVL